

BOLT CIRCLE DIAMETER  
AS REQUIRED

**PLAN VIEW**

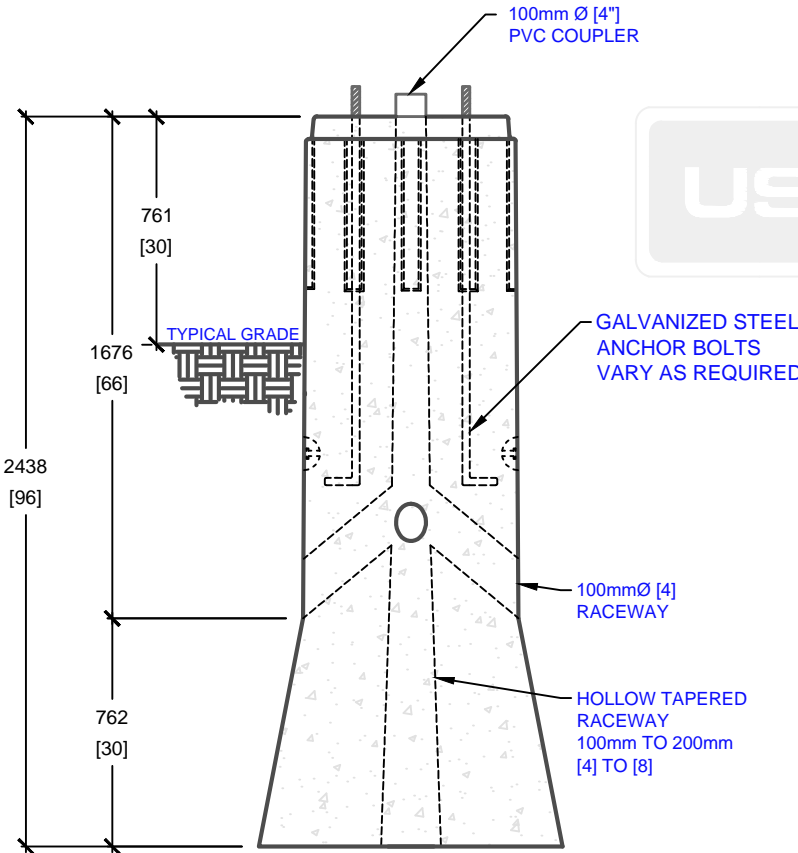

**SIDE ELEVATION**

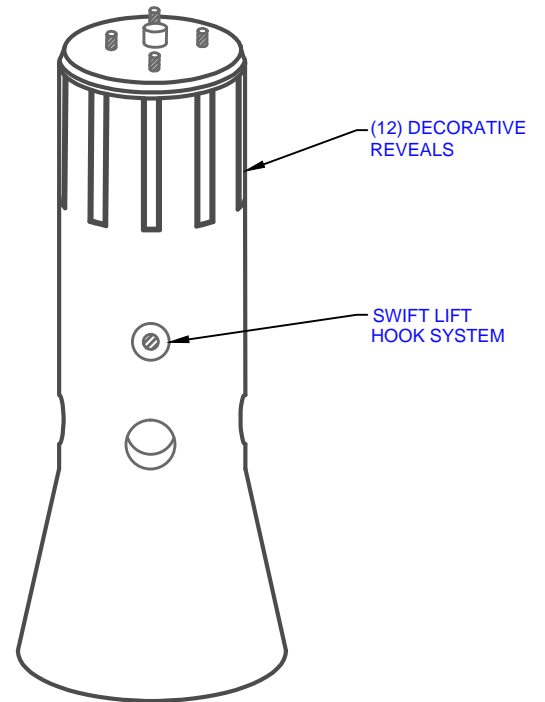

**ISOMETRIC VIEW**

mm  
[Inches]  
ALL DIMENSIONS DEFAULT TO MILLIMETRES



**UTILITY STRUCTURES INC.**

61 BONGARD AVE | OTTAWA, ON | K2E 6V2  
T: 613.225.6398 F: 613.225.1681 TF: 800.267.6466

[www.utilitystructures.com](http://www.utilitystructures.com)

**CONSTRUCTION DETAILS:**

- CAN ACCOMMODATE A 35' POLE ABOVE GRADE
- AVAILABLE IN VARIOUS COLOURS & FINISHES
- ADJUSTABLE BOLT CIRCLE DIAMETER
- BOLT CIRCLE DIAMETER: 203mm[8"] TO 380mm[15"]

- CSA 23.4-05
- 35 MPa (5000psi) AT 28 DAYS
- STRIPPING STRENGTH: MIN. 20 MPa(2900psi)
- 5-8% AIR ENTRAINED
- EXPOSURE CLASS: C-1
- REINFORCING: STEEL TO CSA CAN A23.1

**PRODUCT CODE:**

**P-55DR**

8' DECORATIVE PARKING LOT POLE BASE

**DIMENSIONS:**

**2.44m(H) X 690mm dia.**

**TOTAL WEIGHT:**

**3,000 kg / 6,600 lbs**

**REVISION DATE:**

**JULY 31, 2018**

**REV. # 2**