

BOLT CIRCLE DIAMETER:
200mm[8"] TO 510mm[20"]
(AS REQUIRED)

PLAN VIEW

GALVANIZED STEEL ANCHOR BOLTS
VARY AS REQUIRED

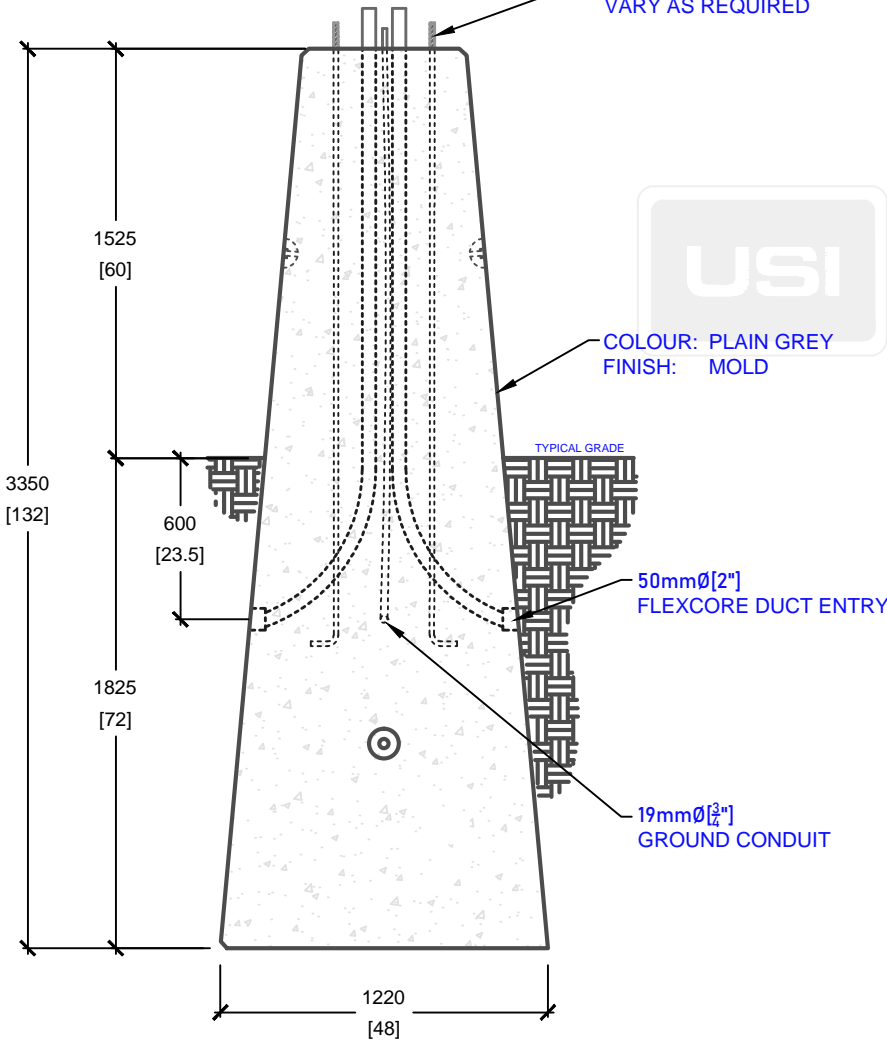

COLOUR: PLAIN GREY
FINISH: MOLD

TYPICAL GRADE

50mmØ[2"]
FLEXCORE DUCT ENTRY

19mmØ[3/4"]
GROUND CONDUIT

SIDE VIEW

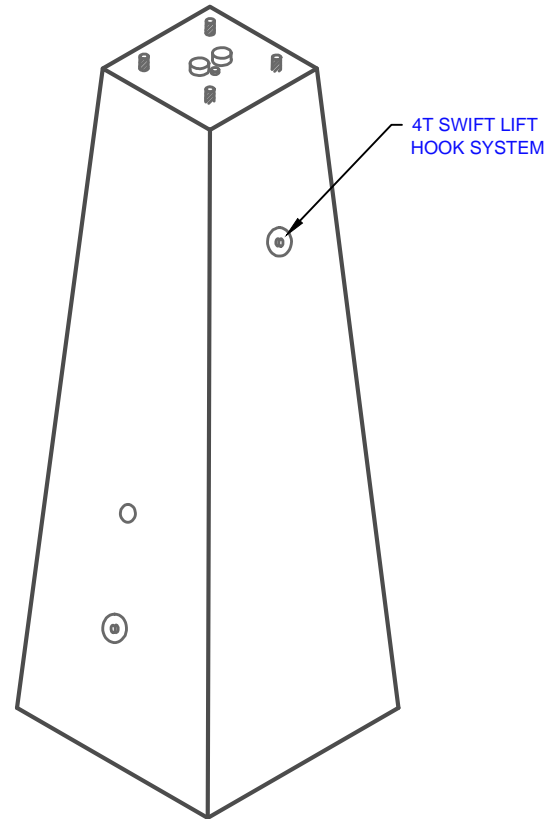

4T SWIFT LIFT
HOOK SYSTEM

ISOMETRIC VIEW

mm
[Inches]
ALL DIMENSIONS DEFAULT TO MILLIMETRES



UTILITY STRUCTURES INC.

61 BONGARD AVE | OTTAWA, ON | K2E 6V2
T: 613.225.6398 F: 613.225.1681 TF: 800.267.6466

www.utilitystructures.com

CONSTRUCTION DETAILS:

- CAN ACCOMMODATE A 60' POLE ABOVE GRADE
- AVAILABLE IN VARIOUS COLOURS & FINISHES
- ADJUSTABLE BOLT CIRCLE DIAMETER
- BOLT CIRCLE DIAMETER: 200mm[8"] TO 510mm[20"]

- CSA 23.4-05
- 45 MPa (6525psi) AT 28 DAYS
- STRIPPING STRENGTH: MIN. 20 MPa(2900psi)
- 5-8% AIR ENTRAINED
- EXPOSURE CLASS: C-1
- REINFORCING: STEEL TO CSA CAN A23.1

PRODUCT CODE:

P-52-132

11' SQUARE PYRAMID POLE BASE

INSIDE DIMENSIONS:

3.35m(H) X 1220mm x 1220mm

ESTIMATED TOTAL WEIGHT:

7,750 kg / 17,050 lbs

REVISION DATE:

OCTOBER 31, 2019

REV. # 1