

0.15m x 810mm [6" x 32"]  
**WATERTIGHT ELECTRICAL FRAME AND COVER**

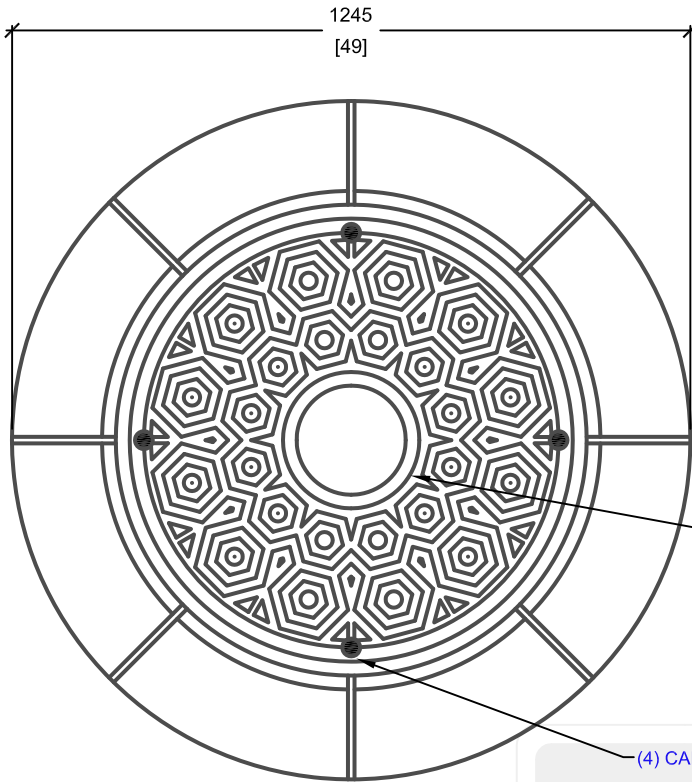

CUSTOM TEXT  
 (EMBOSSING)  
 AVAILABLE  
 ON COVER

(4) CAP SCREWS

**PLAN VIEW**

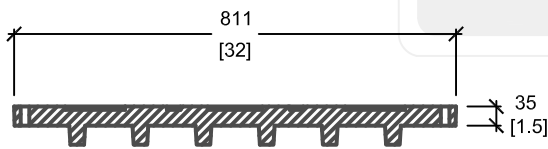
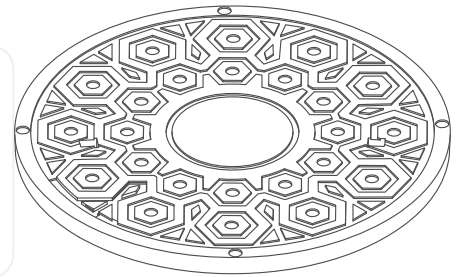

WATERTIGHT GASKET

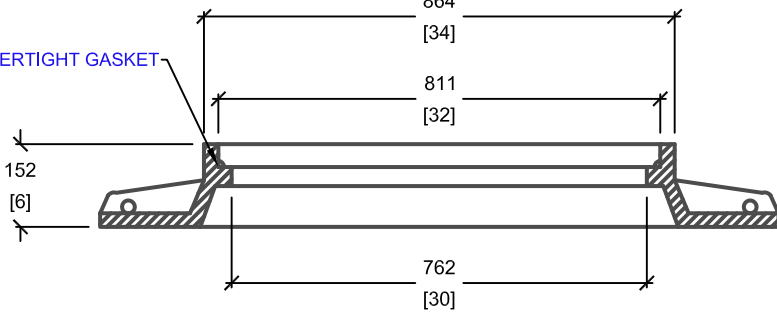

**SIDE ELEVATION**

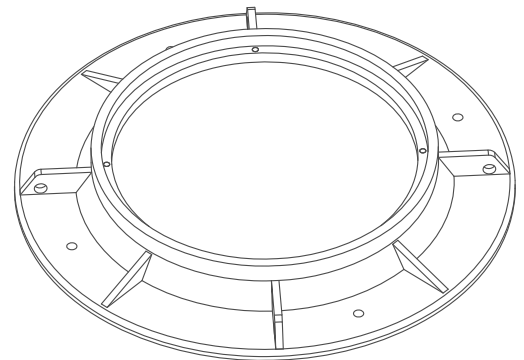

**ISOMETRIC VIEW**

mm  
 [Inches]  
 ALL DIMENSIONS DEFAULT TO MILLIMETRES



**UTILITY STRUCTURES INC.**

61 BONGARD AVE | OTTAWA, ON | K2E 6V2  
 T: 613.225.6398 F: 613.225.1681 TF: 800.267.6466

[www.utilitystructures.com](http://www.utilitystructures.com)

**CONSTRUCTION DETAILS:**

- REFERENCE MODEL # C-43
- WATERTIGHT CAST IRON FRAME & COVER
- CUSTOM TEXT EMBOSING AVAILABLE
- CUSTOM LOGO EMBOSING AVAILABLE

- SUITABLE FOR 762mm[30"] TO 914mm[36"] ACCESS OPENINGS

**PRODUCT CODE:**

**F-5W**

WATERTIGHT ROUND FRAME & ROUND COVER

**DIMENSIONS:**

**0.15m(H) X 811mm DIA.**

**TOTAL WEIGHT:**

**320 kg / 705 lbs**

**REVISION DATE:**

**JUNE 30, 2015**

**REV. # 3**