

CROSS SECTION 'A'

CROSS SECTION 'B'

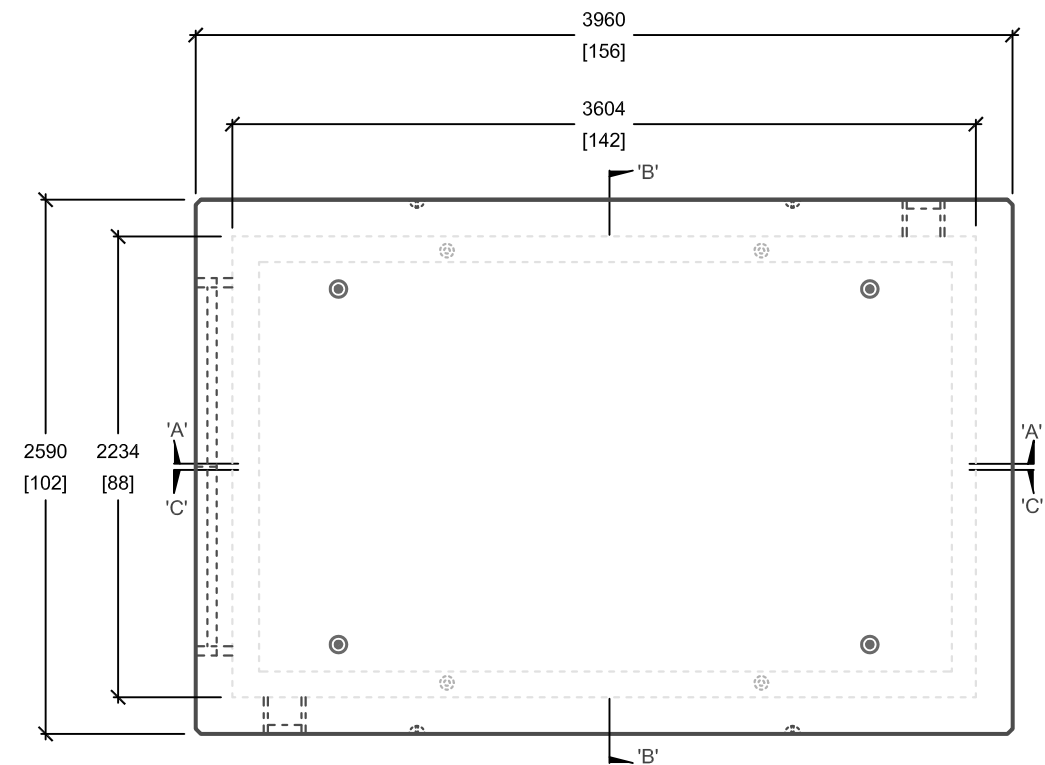

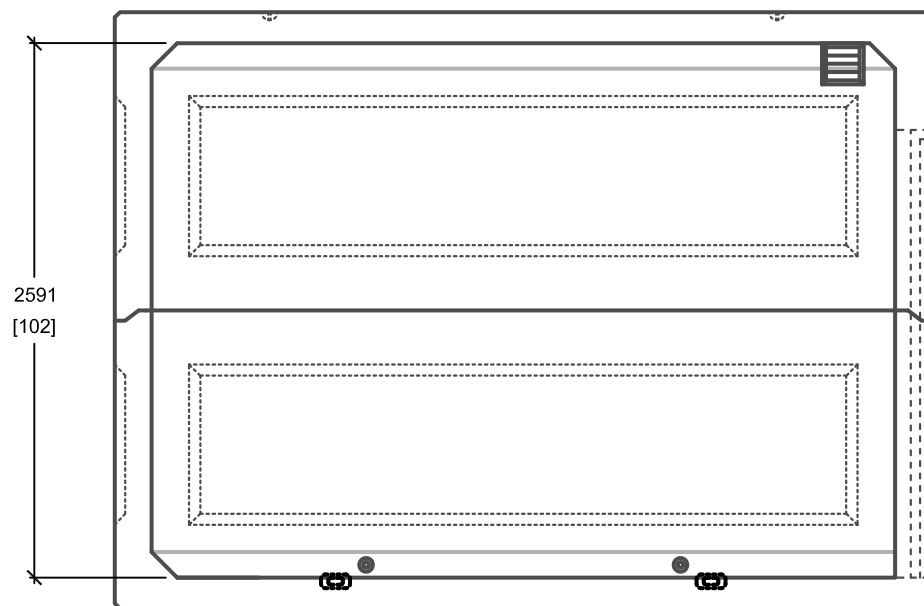

PLAN VIEW

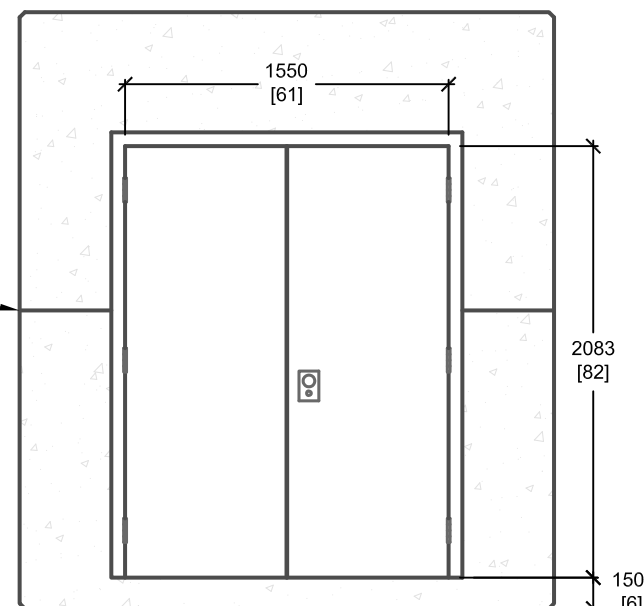

CROSS SECTION 'C'

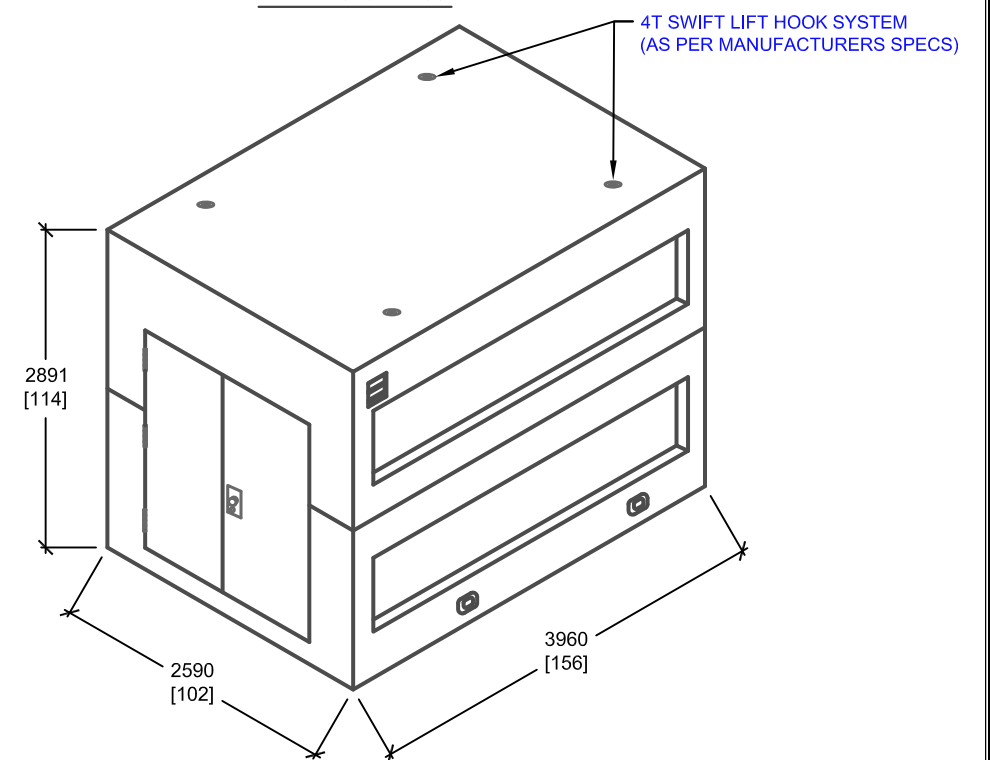

FRONT VIEW

UTILITY STRUCTURES INC.
 61 BONGARD AVE | OTTAWA, ON | K2E 6V2
 T: 613.225.6398 F: 613.225.1681 TF: 800.267.6466
www.utilitystructures.com

PRODUCT DETAILS:
 • 8' x 12' STORAGE SHED

CSA 23.4-05
 - 35 MPa (5000psi) AT 28 DAYS
 - STRIPPING STRENGTH: MIN. 20 MPa(2900psi)
 - 5-8% AIR ENTRAINED
 - EXPOSURE CLASS: C-1
 • REINFORCING: STEEL TO CSA CAN A23.1

NOTES:

- AVAILABLE IN VARIOUS COLOURS & FINISHES
- ALL CORNERS CHAMFERED
- STEEL REINFORCED 178mm [7"] WALLS
- 2590mm [102"] OF HEADROOM
- TWO [8"x8"] ALUMINUM LOUVER VENTS

- POWDER COATED STEEL DOUBLE DOOR
- COMMERCIAL KEYED DEAD BOLT
- NON REMOVABLE PIN (NRP) HINGES
- DOOR OPENING SIZE = 1550mm[61"](W) x 2083mm[82"](H)
- SINGLE DOOR ALSO AVAILABLE, IF REQUIRED
- MAINTENANCE FREE, VANDAL RESISTANT & FIREPROOF
- ALL OTHER ACCESSORIES EXTRA

PRODUCT DETAILS:

- **INSIDE DIMENSIONS:** 2.59m[102"](H) x 2234mm[88"] x 3604mm[142"]
- **OUTSIDE DIMENSIONS:** 2.89m[114"](H) x 2590mm[102"] x 3960mm[156"]
- **ESTIMATED WEIGHTS:**
 TOP: 9,350 kg / 20,570 lbs
 BASE: 9,000 kg / 19,800 lbs

PRODUCT CODE:

E-74

8' x 12' STORAGE SHED

INSIDE DIMENSIONS:
2.89m(H) X 2234mm x 3604mm

ESTIMATED TOTAL WEIGHT:
20,600 kg / 45,320 lbs

REVISION DATE: APRIL 11, 2019 **REV. # 4**