

CROSS SECTION 'A'

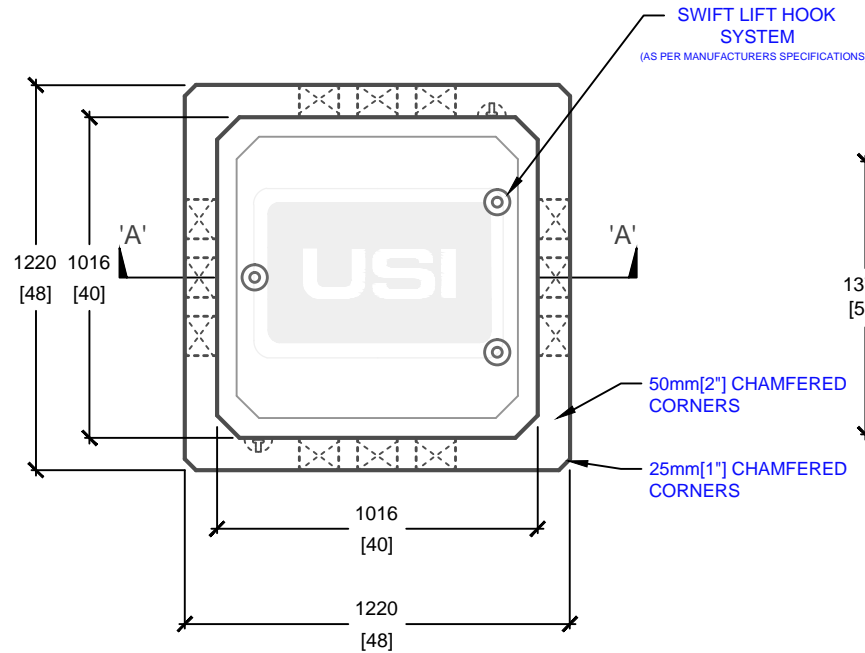

PLAN VIEW

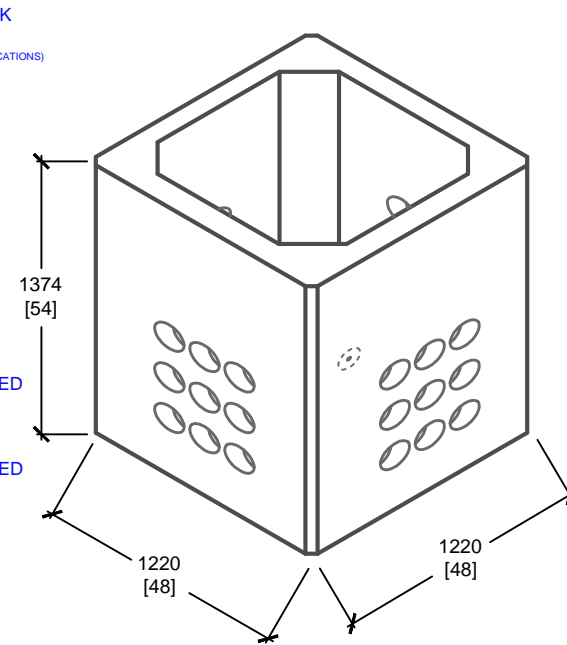

mm
[Inches]
ALL DIMENSIONS DEFAULT TO MILLIMETRES



UTILITY STRUCTURES INC.

61 BONGARD AVE | OTTAWA, ON | K2E 6V2
T: 613.225.6398 F: 613.225.1681 TF: 800.267.6466

www.utilitystructures.com

CONSTRUCTION DETAILS:

- DESIGNED TO CL-625-ONT TRUCK LIVE LOADING AS PER [CSA S6-06](#)
- USE WITH E-644T PAD

• **CSA 23.4**

- 35 MPa (5000psi) AT 28 DAYS
- STRIPPING STRENGTH: MIN. 20 MPa(2900psi)
- 5-8% AIR ENTRAINED
- EXPOSURE CLASS: C-1
- REINFORCING: STEEL TO CSA CAN A23.1

PRODUCT DETAILS:

- (4) 127mm[5"] POLYLOK PIPESEAL WINDOWS (9 POLYLOKS PER WINDOW)
- CLOSED BOTTOM MANHOLE

CUSTOM OPTIONS AVAILABLE:

- CUSTOM WINDOWS, OPENINGS, CABLE RACKS, PULLING EYES & MANHOLE HEIGHT

PRODUCT CODE:

E-644B

4' x 4' ELECTRICAL MANHOLE BASE

OUTSIDE DIMENSIONS:

1.37m(H) X 1220mm x 1220mm

TOTAL WEIGHT:

1,720 kg / 3,785 lbs

REVISION DATE:

November 14 , 2019

REV. # 4