

BULLHORN BRACKETS | Light Duty

! You must select Mounting Option 30 (Steel Tenon) when choosing Bullhorn Brackets.

Select code **30** — **BB#**

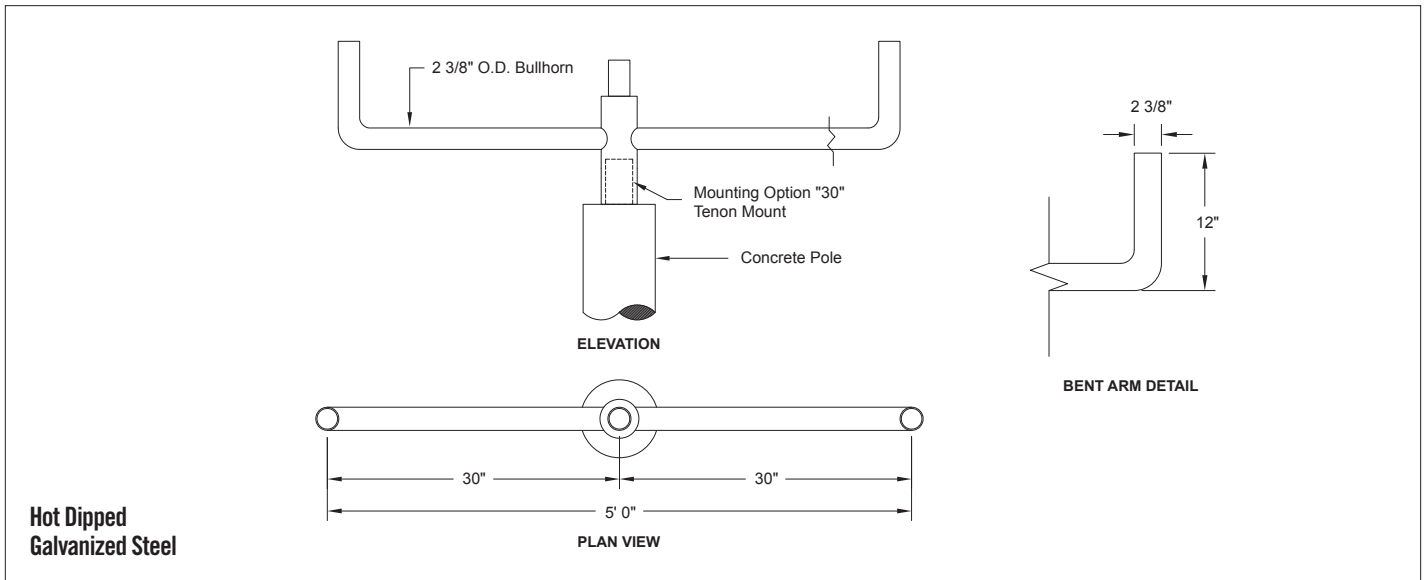

Hot Dipped Galvanized Steel

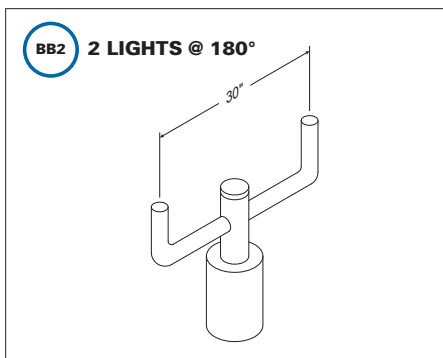

BRACKET CATALOGUE NUMBER	TYP. FIXTURE SPACING [in.]	EPA [sq.ft.]	WEIGHT [lbs.]
BB2	30	1.0	22

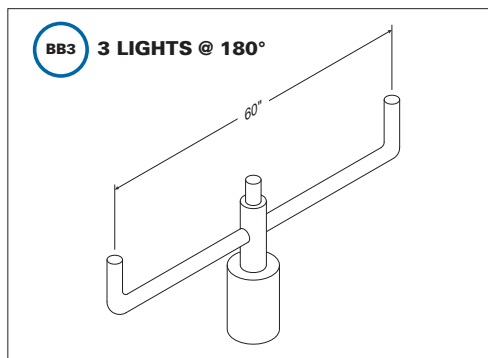

BRACKET CATALOGUE NUMBER	TYP. FIXTURE SPACING [in.]	EPA [sq.ft.]	WEIGHT [lbs.]
BB3	30	1.6	35

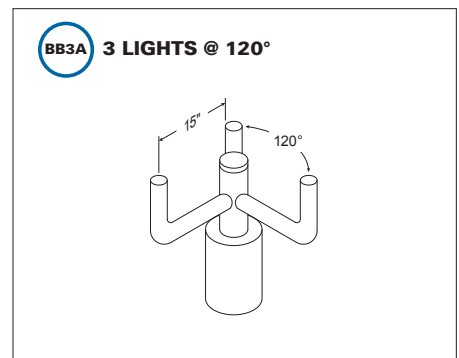

BRACKET CATALOGUE NUMBER	TYP. FIXTURE SPACING [in.]	EPA [sq.ft.]	WEIGHT [lbs.]
BB3A	15	1.8	40

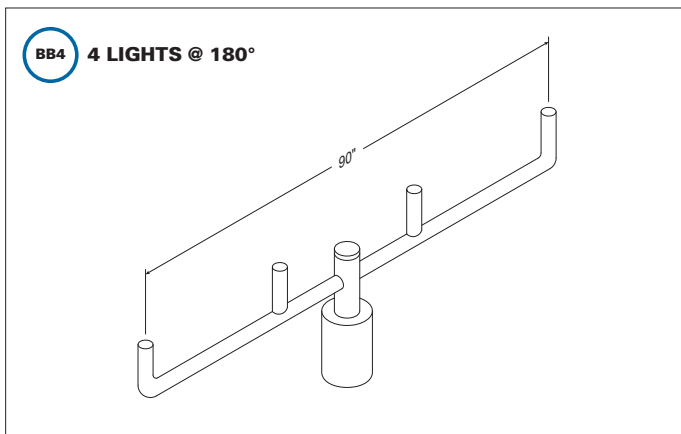

BRACKET CATALOGUE NUMBER	TYP. FIXTURE SPACING [in.]	EPA [sq.ft.]	WEIGHT [lbs.]
BB4	30	2.3	47

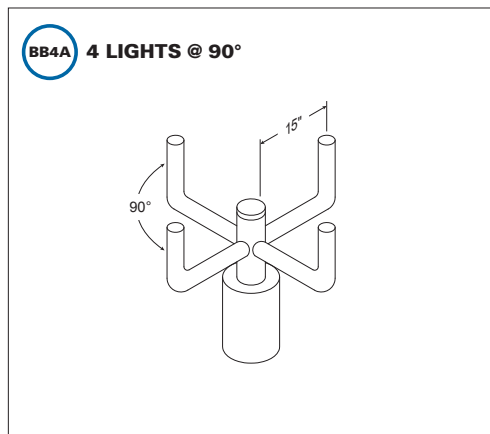

BRACKET CATALOGUE NUMBER	TYP. FIXTURE SPACING [in.]	EPA [sq.ft.]	WEIGHT [lbs.]
BB4A	15	1.6	50

NOTE: All bullhorns are designed to fit a 2 3/8" O.D. x 5" long heavy duty pole tenon.



61 BONGARD AVENUE, OTTAWA, ONTARIO CANADA K2E 6V2
 TEL: [613] 225-6398 • FAX: [613] 225-1681 • TOLL FREE: 1-800-267-6466
 www.utilitystructures.com