

SWIFT LIFT ANCHOR (P52)

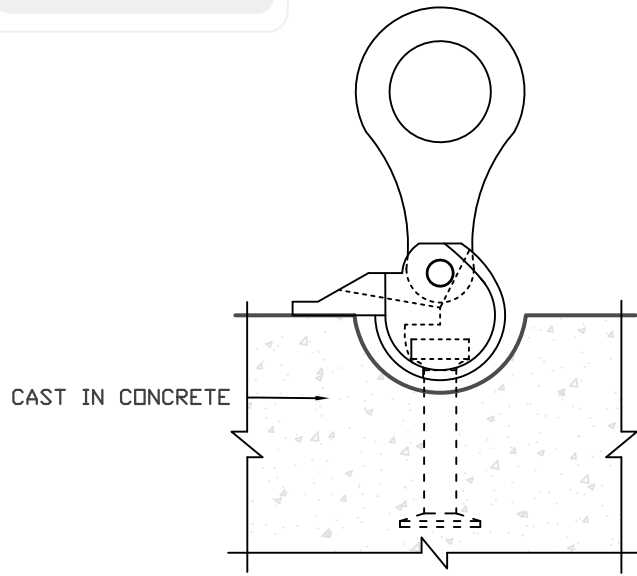
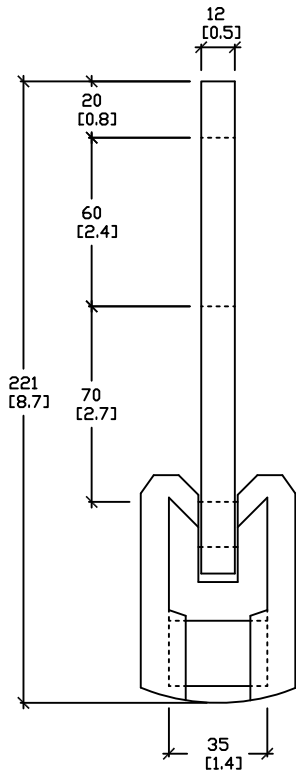

UNIVERSAL LIFTING EYE

SYSTEM INSTALLED

ALL DIMENSIONS DEFAULT TO MILLIMETERS

mm
[in.]



61 BONGARD AVE
OTTAWA, ON,
PH: 800.267.6466
FAX: 613.225.1681

www.utilitystructures.com

NOTES:

P-52 4 TON CAPACITY
OSHA REQ. 4 TO 1 SAFETY FACTOR

REV.#	MM/DD/YYYY	PREP.
1	SEP/16/2008	LRW

SWIFT LIFT

LIFTING SYSTEM

WEIGHT = N/A

100mm (W) X 221mm (H)