

**END ELEVATION**

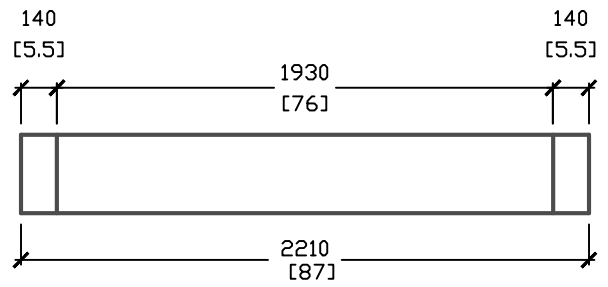

**SIDE ELEVATION**

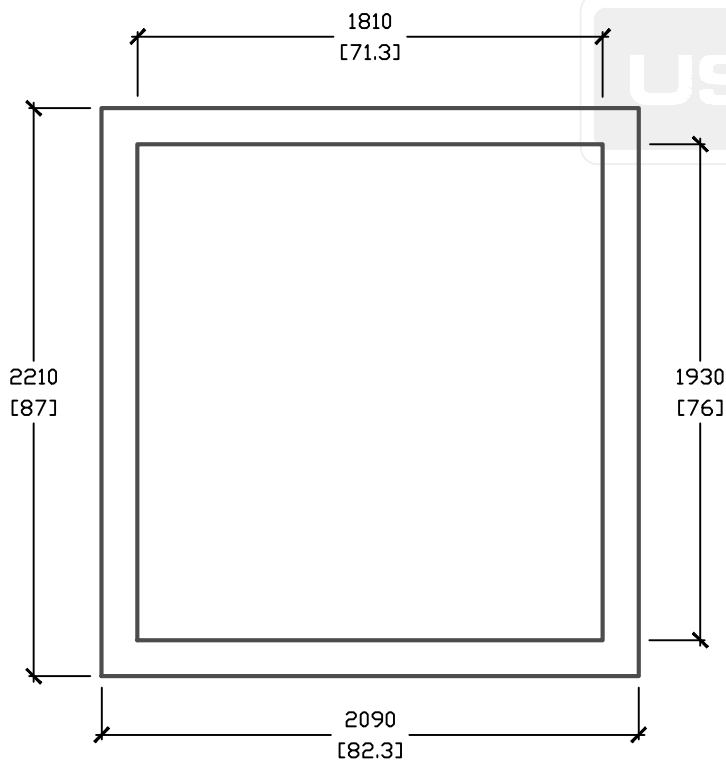

**PLAN VIEW**

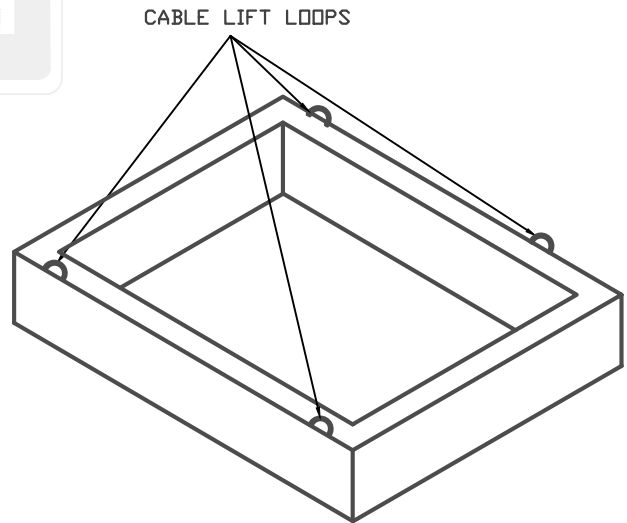

**ISOMETRIC VIEW**

ALL DIMENSIONS DEFAULT TO MILLIMETERS

mm  
[in.]



61 BONGARD AVE  
OTTAWA, ON,  
PH: 800.267.6466  
FAX: 613.225.1681

**NOTES:**  
USED FOR E37 (6'x12') SWITCHGEAR

\*CSA 23.4-05  
35MPa (5000psi) AT 28 DAYS  
6-8% AIR ENTRAINED

**S-8**

SWITCHGEAR ADJUSTER

WEIGHT = 800kg/1764lbs

www.utilitystructures.com

REV.#	MM/DD/YYYY	PREP.
2	FEB/28/2009	LRW
3	MARCH/20/2013	EG

**2210mm x 2090mm [O.D.]**