

**WASHER
PLAN VIEW**
THICK = 6mm [0.25"]

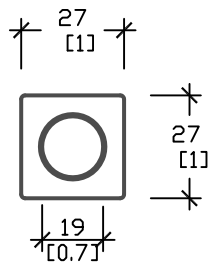

**NUT
PLAN VIEW**

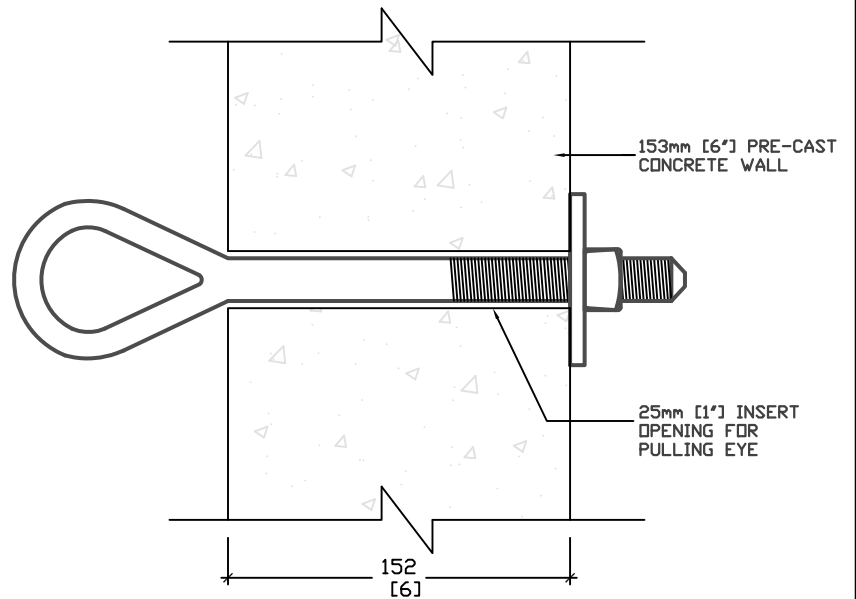

**PULLING EYE
APPLICATION**

ALL DIMENSIONS DEFAULT TO MILLIMETERS

mm
[in.]



61 BONGARD AVE
OTTAWA, ON,
PH: 800.267.6466
FAX: 613.225.1681

www.utilitystructures.com

NOTES:

HOT DIPPED GALVANIZED STEEL
MIN. BREAKING STRENGTH = 20,050lbs
STANDARD 8" LONG
AVAILABLE IN DIFFERENT LENGTHS

REV.#	MM/DD/YYYY	PREP.
2	SEP/16/2008	LRW

PULLING EYE
OVAL EYE BOLT

WEIGHT = N/A

19mm dia. x 200mm(L)