

PRODUCT CODE	POLE HEIGHT (ft.)	BASE BURIAL DEPTH (ft.)	OVERALL LENGTH "X" (ft.)	WEIGHT (kg/lbs.)
P-50-20DR(8)	10-15	5	8	1,250kg / 2,750lbs
P-50-20DR(9)	16-20	6	9	1,400kg / 3,100lbs
P-50-20DR(10)	21-25	7	10	1,550kg / 3,400lbs
P-50-20DR(11)	26-30	8	11	1,700kg / 3,750lbs
P-50-20DR(12)	31-35	9	12	1,850kg / 4,100lbs

* BASE BURIAL DEPTH SUBJECT TO SOIL CONDITIONS, REFER TO SOIL REPORT

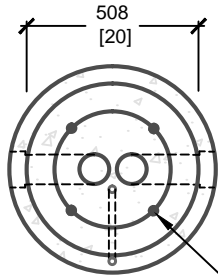

PLAN VIEW

BOLT CIRCLE DIAMETER AS REQUIRED

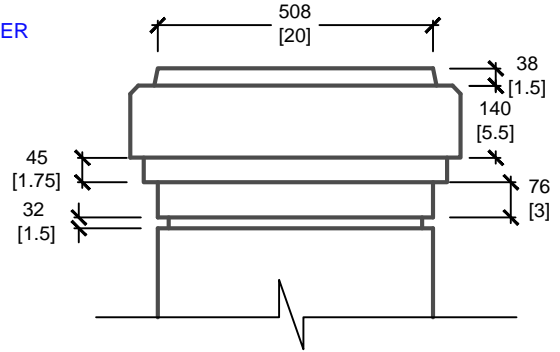

ISOMETRIC VIEW

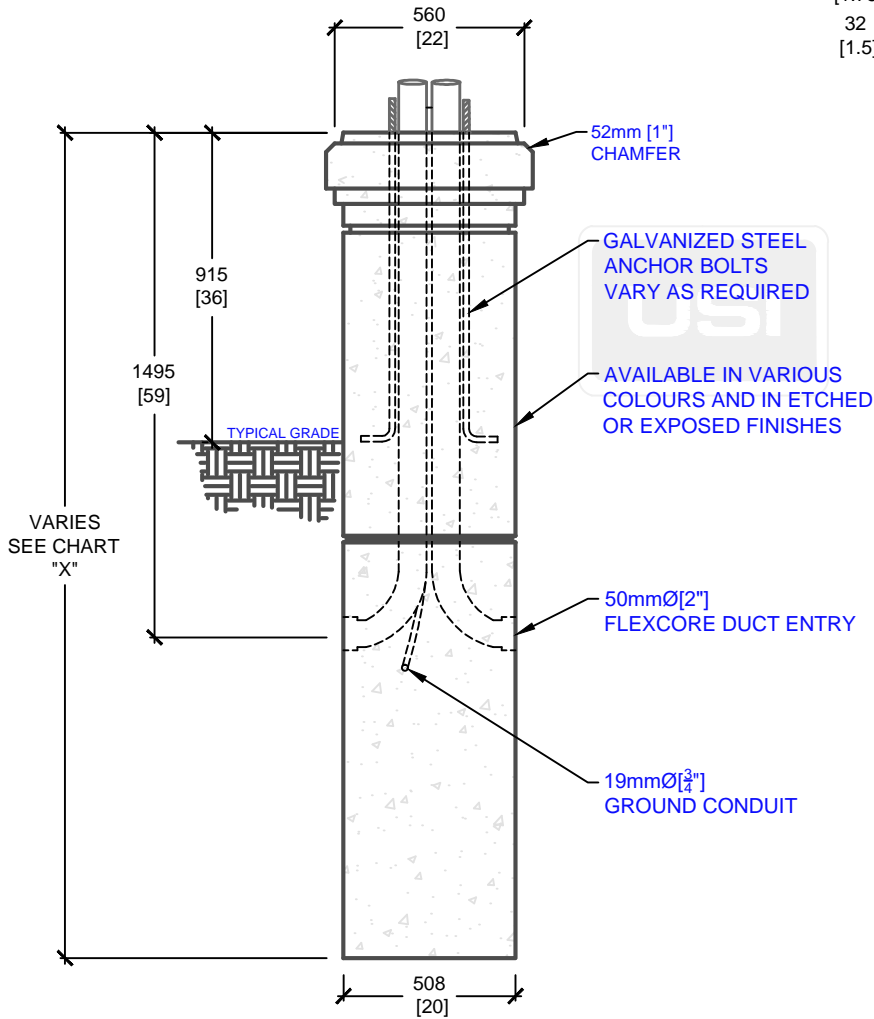

SIDE ELEVATION

VARIES SEE CHART "X"

mm
[Inches]
ALL DIMENSIONS DEFAULT TO MILLIMETRES



UTILITY STRUCTURES INC.

61 BONGARD AVE | OTTAWA, ON | K2E 6V2
T: 613.225.6398 F: 613.225.1681 TF: 800.267.6466

www.utilitystructures.com

CONSTRUCTION DETAILS:

- ACCOMMODATES VARIOUS POLE HEIGHTS
- AVAILABLE IN VARIOUS COLOURS & FINISHES
- ADJUSTABLE BOLT CIRCLE DIAMETER
- BOLT CIRCLE DIAMETER: 150mm[6"] TO 305mm[12"]

- CSA 23.4-05
- 35 MPa (5000psi) AT 28 DAYS
- STRIPPING STRENGTH: MIN. 20 MPa(2900psi)
- 5-8% AIR ENTRAINED
- EXPOSURE CLASS: C-1
- REINFORCING: STEEL TO CSA CAN A23.1

PRODUCT CODE:

P-50-20DR(H)
20" DECORATIVE PARKING LOT POLE BASE

DIMENSIONS:

VARIES(H) X 508mm dia.

TOTAL WEIGHT:

VARIES

REVISION DATE:

JULY 31, 2018

REV. # 2