

0.15m x 810mm [6" x 32"]  
ELECTRICAL FRAME AND COVER TAMPER PROOF

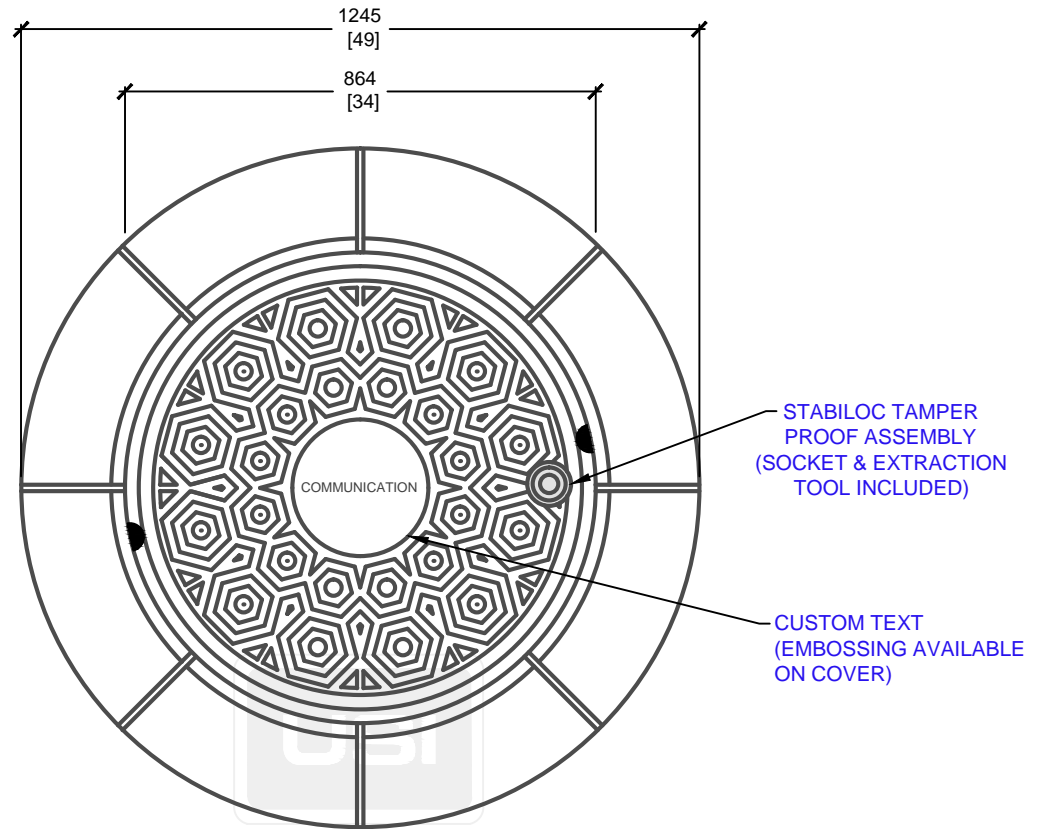

**PLAN VIEW**

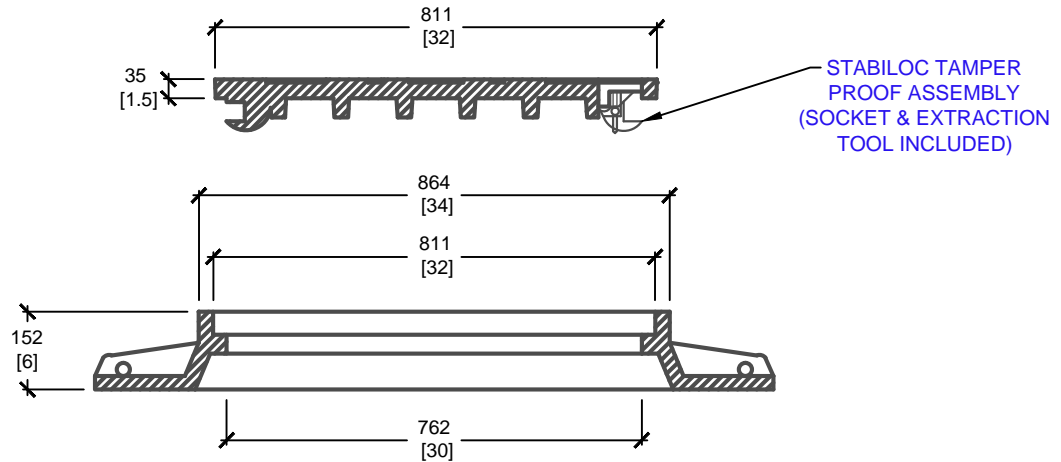

**SIDE ELEVATION**

mm  
[Inches]  
ALL DIMENSIONS DEFAULT TO MILLIMETRES



**UTILITY STRUCTURES INC.**

61 BONGARD AVE | OTTAWA, ON | K2E 6V2  
T: 613.225.6398 F: 613.225.1681 TF: 800.267.6466

[www.utilitystructures.com](http://www.utilitystructures.com)

**CONSTRUCTION DETAILS:**

- SIMILAR TO C-43A
- WITH STABILOC SECURITY SYSTEM
- USED FOR 940mm DIA. OPENING

- FOR USE ON: E-26, E-35, E-36, E-37, E-38, E-39 & E-812

**PRODUCT CODE:**

**F-5-TP**

ROUND FRAME & ROUND COVER  
C/W TAMPER PROOF ASSEMBLY

**DIMENSIONS:**

**.15m(H) x 811mm DIA.**

**TOTAL WEIGHT:**

**320 kg / 750 lbs**

**REVISION DATE:**

**SEPTEMBER 12, 2017**

**REV. # 2**