

150mm x 625mm dia. [6"x25"] MANHOLE FRAME & COVER
 SQUARE FRAME ROUND COVER - WATERTIGHT
 (O.P.S.D. #401.03)

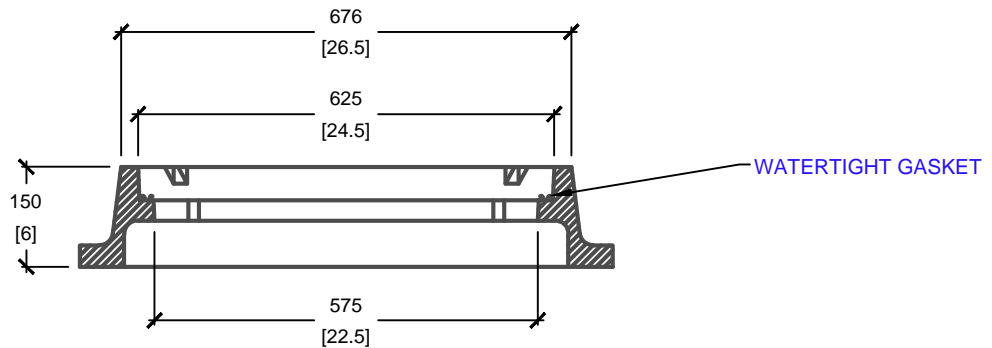

SIDE ELEVATION

mm
 [Inches]
 ALL DIMENSIONS DEFAULT TO MILLIMETRES

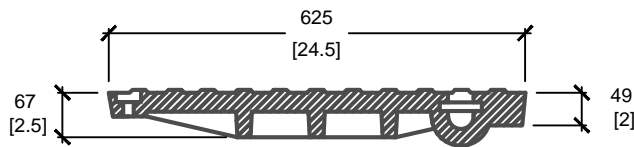
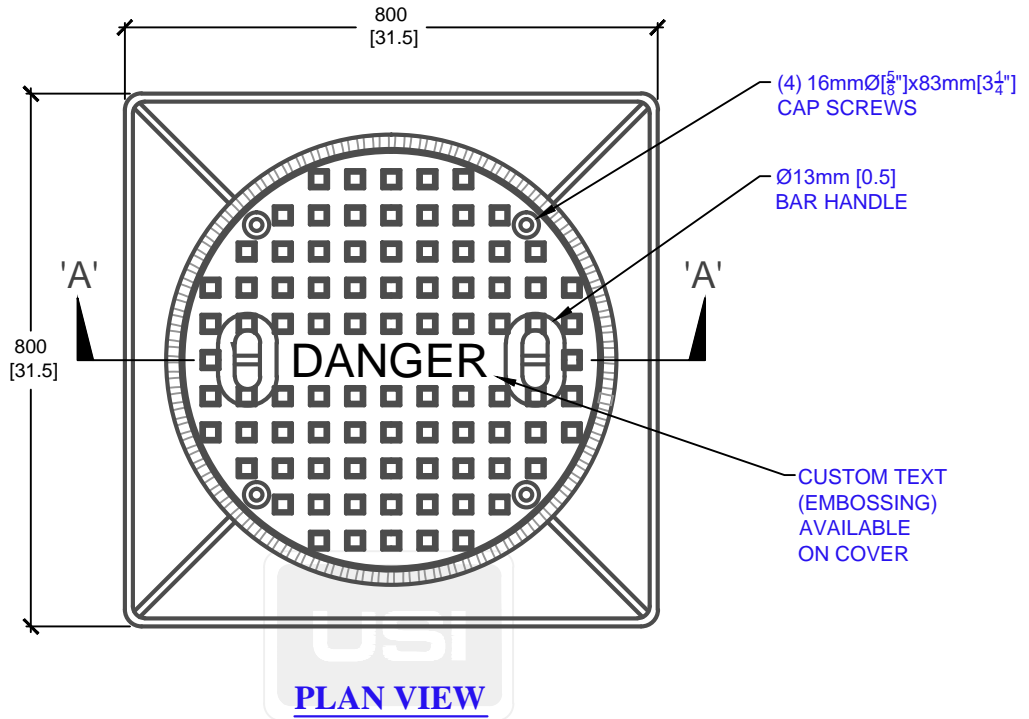

UTILITY STRUCTURES INC.

61 BONGARD AVE | OTTAWA, ON | K2E 6V2
 T: 613.225.6398 F: 613.225.1681 TF: 800.267.6466

www.utilitystructures.com

CONSTRUCTION DETAILS:

- AS PER OPSD 401.03
- WATERTIGHT CAST IRON FRAME & COVER
- CUSTOM TEXT EMBOSSING AVAILABLE
- CUSTOM LOGO EMBOSSING AVAILABLE

- FOR USE ON: E-1B/E-3, E-20, E-22, E-23, E-24, E-25, E-29, E-60/E-61, E-62/E-63

PRODUCT CODE:

F-2

WATERTIGHT FRAME & ROUND COVER

DIMENSIONS:

0.15m(H) x 625mm DIA.

TOTAL WEIGHT:

175 kg / 385 lbs

REVISION DATE:

SEPTEMBER 12, 2017

REV. # 5