

PLAN VIEW

NOTE
 PLANTER BOX IS FILLED WITH CONCRETE TO A HEIGHT OF 381mm [15"] FROM INSIDE BOTTOM. THIS ALLOWS FOR EXTRA SECURITY AND WEIGHT, WHILE STILL ALLOWING 381mm [15"] x 1138mm [45"] X 1138 [45"] TO PLANT

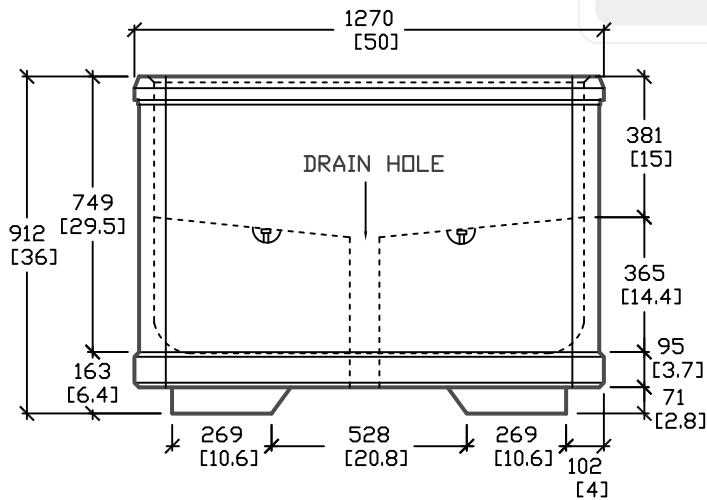

ELEVATION

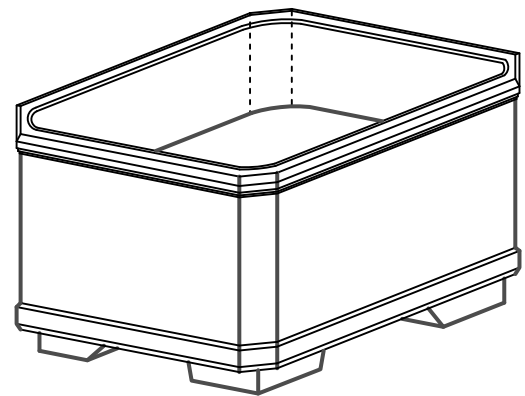

ISOMETRIC

ALL DIMENSIONS DEFAULT TO MILLIMETERS

mm
[in.]



61 BONGARD AVE
 OTTAWA, ON,
 PH: 800.267.6466
 FAX: 613.225.1681

www.utilitystructures.com

NOTES:

AVAILABLE IN VARIOUS
 COLOURS AND FINISHES

*CSA 23.4-05
 35MPa (5000psi) AT 28 DAYS
 6-8% AIR ENTRAINED

| REV.# | MM/DD/YYYY | PREP. |
|-------|-------------|-------|
| 1 | SEP/12/2008 | LRW |
| 2 | MAR/02/2009 | LRW |

E-97

SECURITY PLANTER BOX

WEIGHT = 1910kg/5000lbs

1220mm x 1220mm [O.D.]