

**GENERAL NOTES**

- AVAILABLE IN VARIOUS COLORS & FINISHES
- CAN BE PAINTED OR SEALED WITH ANTI-GRAFFITI
- ALL CORNERS CHAMFERED
- STEEL REINFORCED 127mm [5"] WALLS
- 2160mm [85"] OF HEADROOM
- TWO [8"x8"] ALUMINUM LOUVER VENTS
- C/W NON REMOVABLE PIN (NRP) HINGES
- COMMERCIAL KEYED DEAD BOLT
- CORROSION-RESISTANT DOUBLE DOOR
- DOOR OPENING SIZE = 61"(W) x 82"(H)

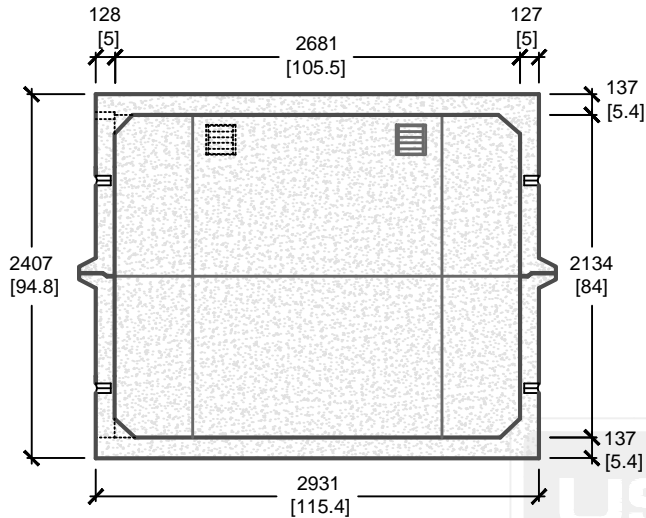

**CROSS SECTION 'A'**

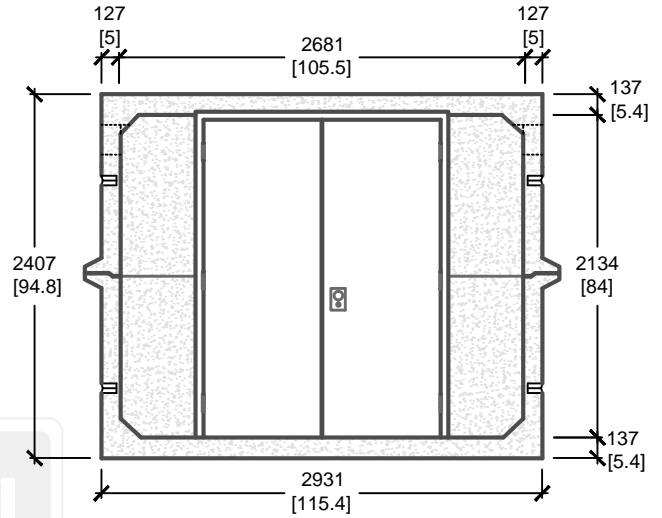

**FRONT VIEW**

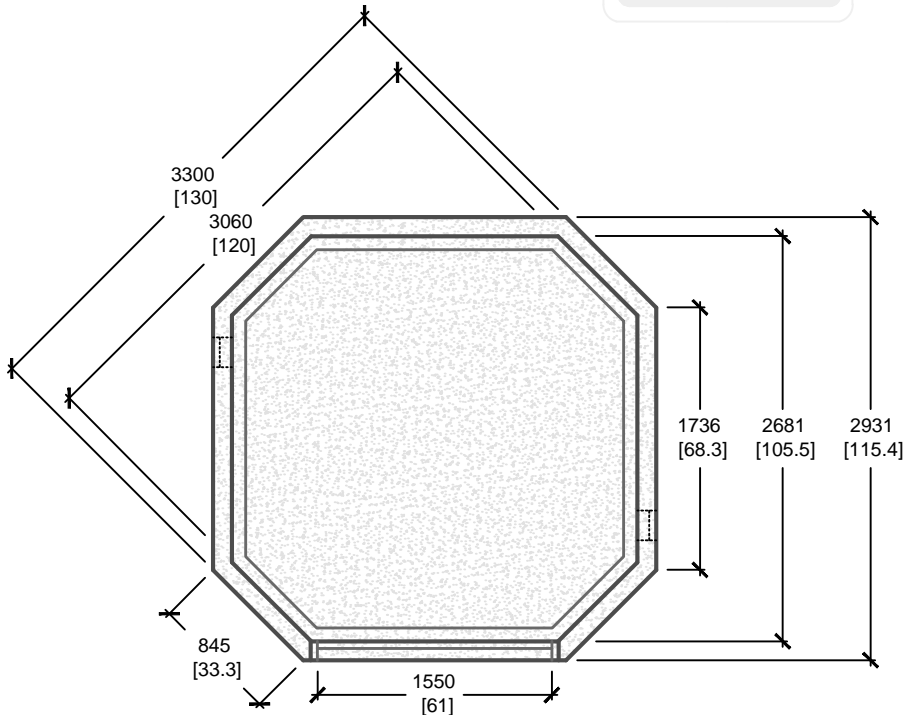

**PLAN VIEW**

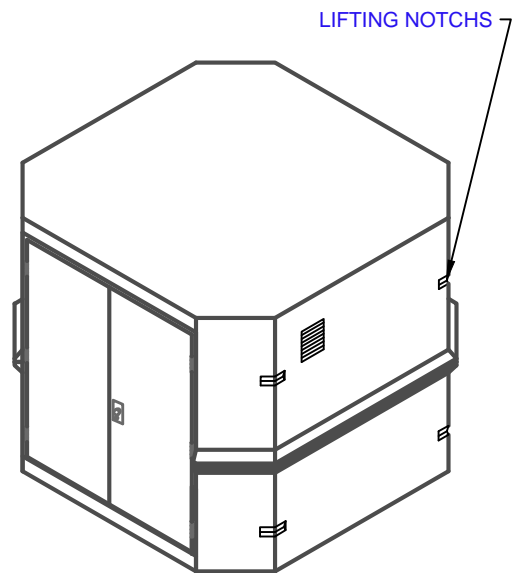

**ISOMETRIC VIEW**

mm  
[Inches]  
ALL DIMENSIONS DEFAULT TO MILLIMETRES



**UTILITY STRUCTURES INC.**

61 BONGARD AVE | OTTAWA, ON | K2E 6V2  
T: 613.225.6398 F: 613.225.1681 TF: 800.267.6466

[www.utilitystructures.com](http://www.utilitystructures.com)

**CONSTRUCTION DETAILS:**

• SEE GENERAL NOTES

- CSA 23.4-05
- 35 MPa (5000psi) AT 28 DAYS
- STRIPPING STRENGTH: MIN. 20 MPa(2900psi)
- 5-8% AIR ENTRAINED
- EXPOSURE CLASS: C-1
- REINFORCING: STEEL TO CSA CAN A23.1

PRODUCT CODE:

**E-73**

10' x 10' CONCRETE STORAGE SHED

INSIDE DIMENSIONS:

**2.13m(H) x 3060mm x 3060mm**

TOTAL WEIGHT:

**11,800 kg / 25,960 lbs**

REVISION DATE:

**SEPTEMBER 14, 2017**

REV. #6