

**GENERAL NOTES**

- TWO [8"x8"] ALUMINUM LOUVER VENTS
- NON REMOVABLE PIN (NRP) HINGES
- COMMERCIAL KEYED DEAD BOLT
- 18ga POWDER COATED STEEL SINGLE DOOR INSTALLED
- DOOR OPENING SIZE = 33"(W) x 74"(H)

**AVAILABLE OPTIONS**

- 16ga POWDER COATED SINGLE DOOR AVAILABLE
- CUSTOM COLOURS OR FINISHES
- CUSTOM HARDWARE AVAILABLE UPON REQUEST

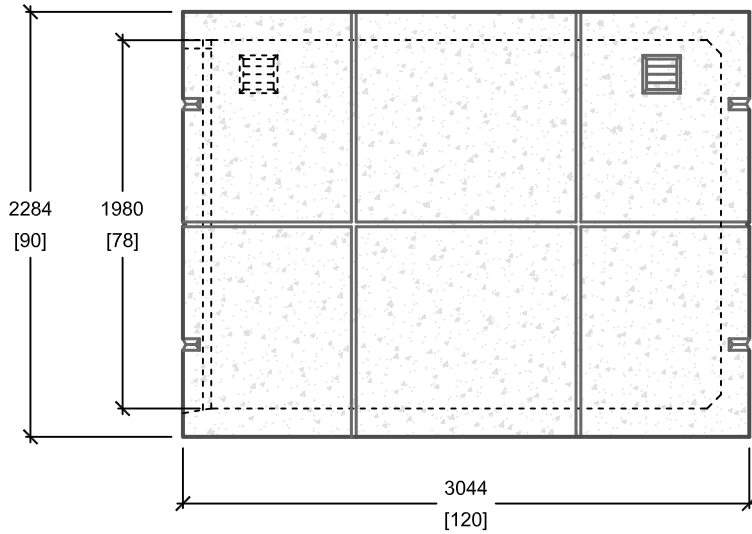

**SIDE ELEVATION**

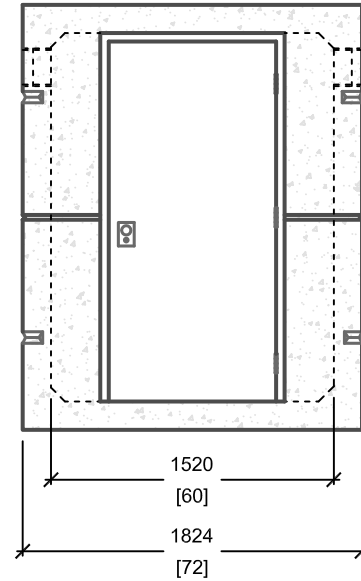

**FRONT VIEW**

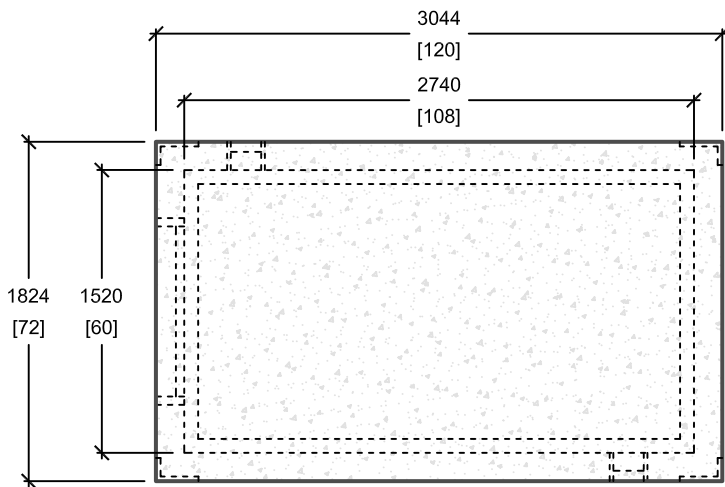

**PLAN VIEW**

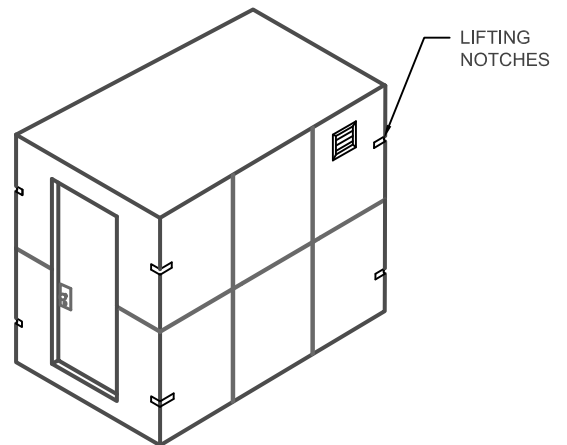

**ISOMETRIC VIEW**

mm  
[Inches]  
ALL DIMENSIONS DEFAULT TO MILLIMETRES



**UTILITY STRUCTURES INC.**

61 BONGARD AVE | OTTAWA, ON | K2E 6V2  
T: 613.225.6398 F: 613.225.1681 TF: 800.267.6466

[www.utilitystructures.com](http://www.utilitystructures.com)

**CONSTRUCTION DETAILS:**

- AVAILABLE IN VARIOUS COLOURS & FINISHES
- ALL CORNERS CHAMFERED
- 1980mm[78"] INSIDE HEADROOM
- STEEL REINFORCED 152mm[6"] WALLS
- MAINTENANCE FREE, VANDAL RESISTANT & FIREPROOF
- SEE GENERAL NOTES FOR HARDWARE

- CSA 23.4-05
- 35 MPa (5000psi) AT 28 DAYS
- STRIPPING STRENGTH: MIN. 20 MPa(2900psi)
- 5-8% AIR ENTRAINED
- EXPOSURE CLASS: C-1
- REINFORCING: STEEL TO CSA CAN A23.1

**PRODUCT CODE:**

**E-71**

5' x 9' CONCRETE STORAGE SHED

**DIMENSIONS:**

**2.28m(H) x 1520mm x 2740mm**

**TOTAL WEIGHT:**

**9,500 kg / 20,094 lbs**

**REVISION DATE:**

**JUNE 16, 2016**

**REV. # 3**