

PRODUCT CODE	POLE HEIGHT (ft.)	BASE BURIAL DEPTH (ft.)	OVERALL LENGTH "X" (ft.)	WEIGHT (ESTIMATED) (kg/lbs.)
E-59(8)	10-15	5	8	1,400kg / 3,100lbs
E-59(9)	16-25	6	9	1,550kg / 3,400lbs
E-59(10)	26-35	7	10	1,700kg / 3,750lbs
E-59(11)	36-45	8	11	1,900kg / 4,200lbs
E-59(12)	46-50	9	12	2,100kg / 4,620lbs

\* BASE BURIAL DEPTH SUBJECT TO SOIL CONDITIONS, REFER TO SOIL REPORT  
 \* HEIGHT ABOVE GRADE: 3 FEET (TYPICAL)

BOLT CIRCLE DIAMETER  
AS REQUIRED

**PLAN VIEW**

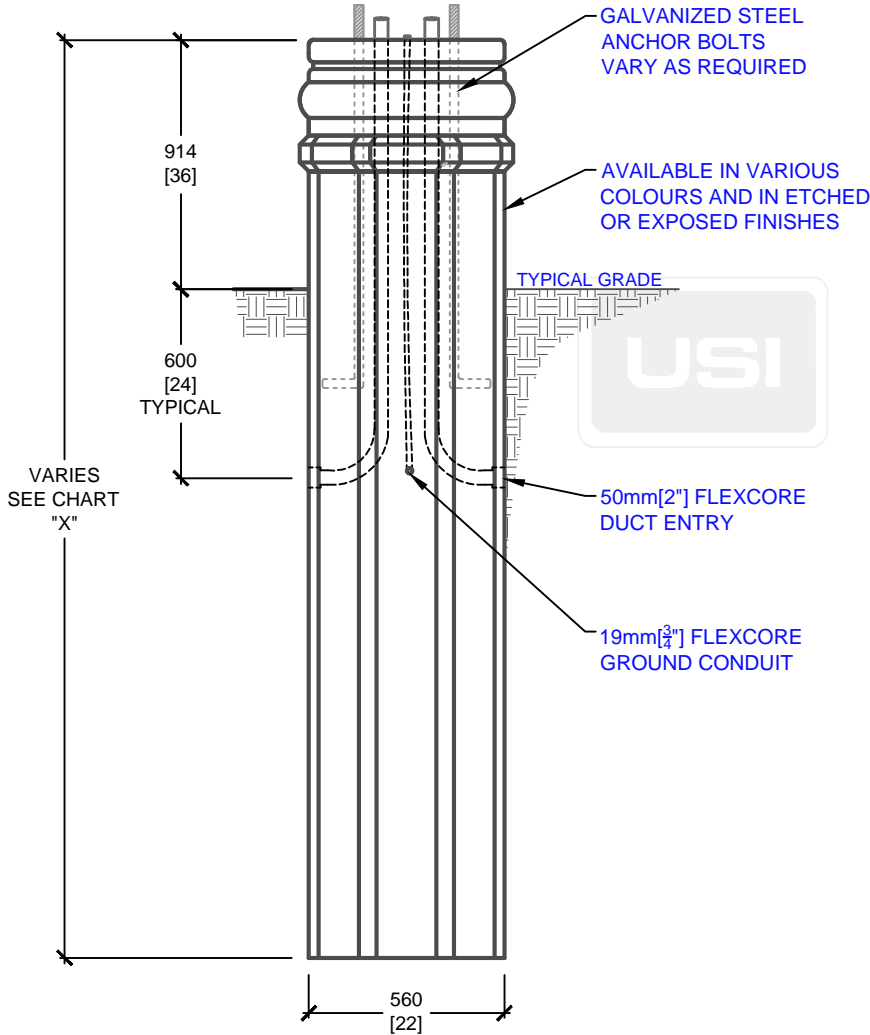

**SIDE ELEVATION**

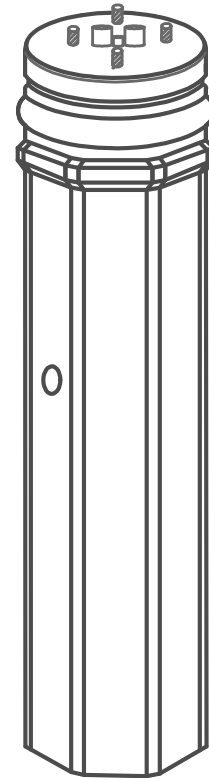

**ISOMETRIC VIEW**

mm  
[Inches]  
ALL DIMENSIONS DEFAULT TO MILLIMETRES



**UTILITY STRUCTURES INC.**

61 BONGARD AVE | OTTAWA, ON | K2E 6V2  
 T: 613.225.6398 F: 613.225.1681 TF: 800.267.6466

[www.utilitystructures.com](http://www.utilitystructures.com)

**CONSTRUCTION DETAILS:**

- ACCOMMODATES VARIOUS POLE HEIGHTS
- AVAILABLE IN VARIOUS COLOURS & FINISHES
- ADJUSTABLE BOLT CIRCLE DIAMETER
- BOLT CIRCLE DIAMETER: 150mm[6"] TO 380mm[15"]

- CSA 23.4-05
- 45 MPa (6525psi) AT 28 DAYS
- STRIPPING STRENGTH: MIN. 20 MPa(2900psi)
- 5-8% AIR ENTRAINED
- EXPOSURE CLASS: C-1
- REINFORCING: STEEL TO CSA CAN A23.1

**PRODUCT CODE:**

**E-59(H)**

DECORATIVE PARKING LOT POLE BASE

**INSIDE DIMENSIONS:**

**VARIES(H) X 560mm dia.**

**TOTAL WEIGHT:**

**VARIES**

**REVISION DATE:**

**MAY 19, 2017**

**REV. # 1**