

- CUSTOM BOLT CIRCLE DIAMETER AVAILABLE
- CUSTOM DUCT ENTRIES AVAILABLE

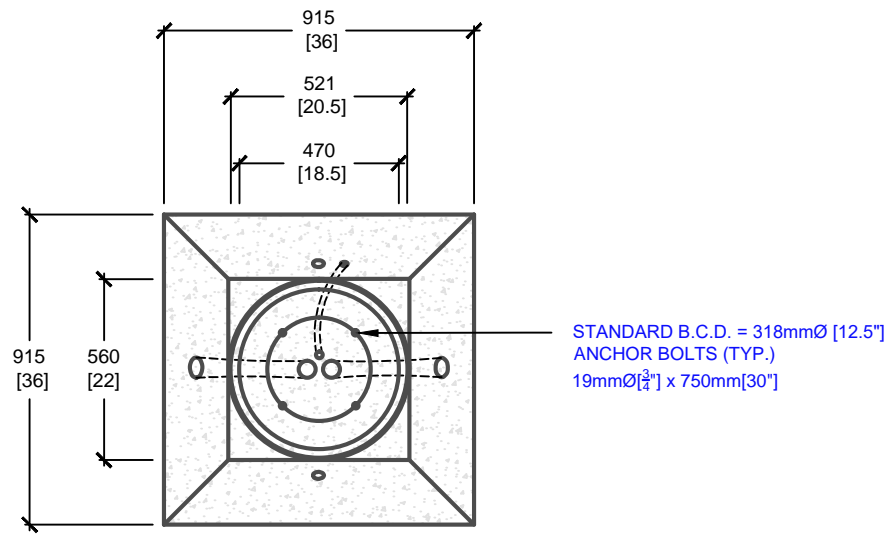

PLAN VIEW

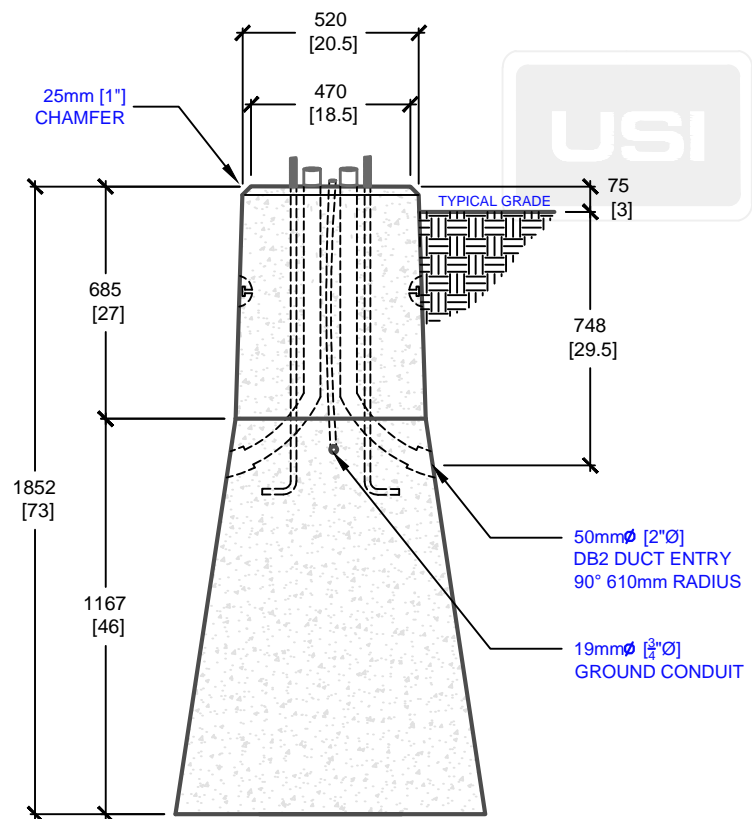

SIDE ELEVATION

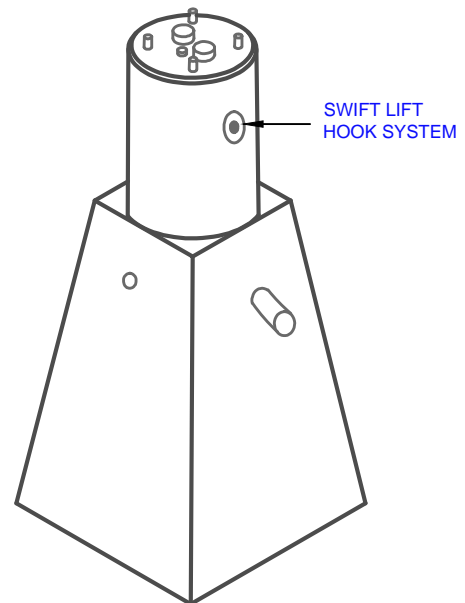

ISOMETRIC VIEW

mm
[Inches]
ALL DIMENSIONS DEFAULT TO MILLIMETRES



UTILITY STRUCTURES INC.
61 BONGARD AVE | OTTAWA, ON | K2E 6V2
T: 613.225.6398 F: 613.225.1681 TF: 800.267.6466
www.utilitystructures.com

CONSTRUCTION DETAILS:

- AS PER CITY OF OTTAWA LID002B TYPE "A"
- CAN ACCOMMODATE A 37' POLE ABOVE GRADE
- BOLT CIRCLE DIAMETER: 318mmØ [12.5"Ø]
- CUSTOM BOLT CIRCLE DIAMETER AVAILABLE

- CSA 23.4-05
- 35 MPa (5000psi) AT 28 DAYS
- STRIPPING STRENGTH: MIN. 20 MPa(2900psi)
- 5-8% AIR ENTRAINED
- EXPOSURE CLASS: C-1
- REINFORCING: STEEL TO CSA CAN A23.1

PRODUCT CODE:	E-52RT	
	6' SQUARE PYRAMID POLE BASE WITH ROUND TOP	
DIMENSIONS:	1.85m(H) X 470mm dia.	
TOTAL WEIGHT:	1,977 kg / 4,360 lbs	
REVISION DATE:	MAY 18, 2017	REV. #1