

BOLT CIRCLE DIAMETER:  
200mm[8"] TO 510mm[20"]  
(AS REQUIRED)

**PLAN VIEW**

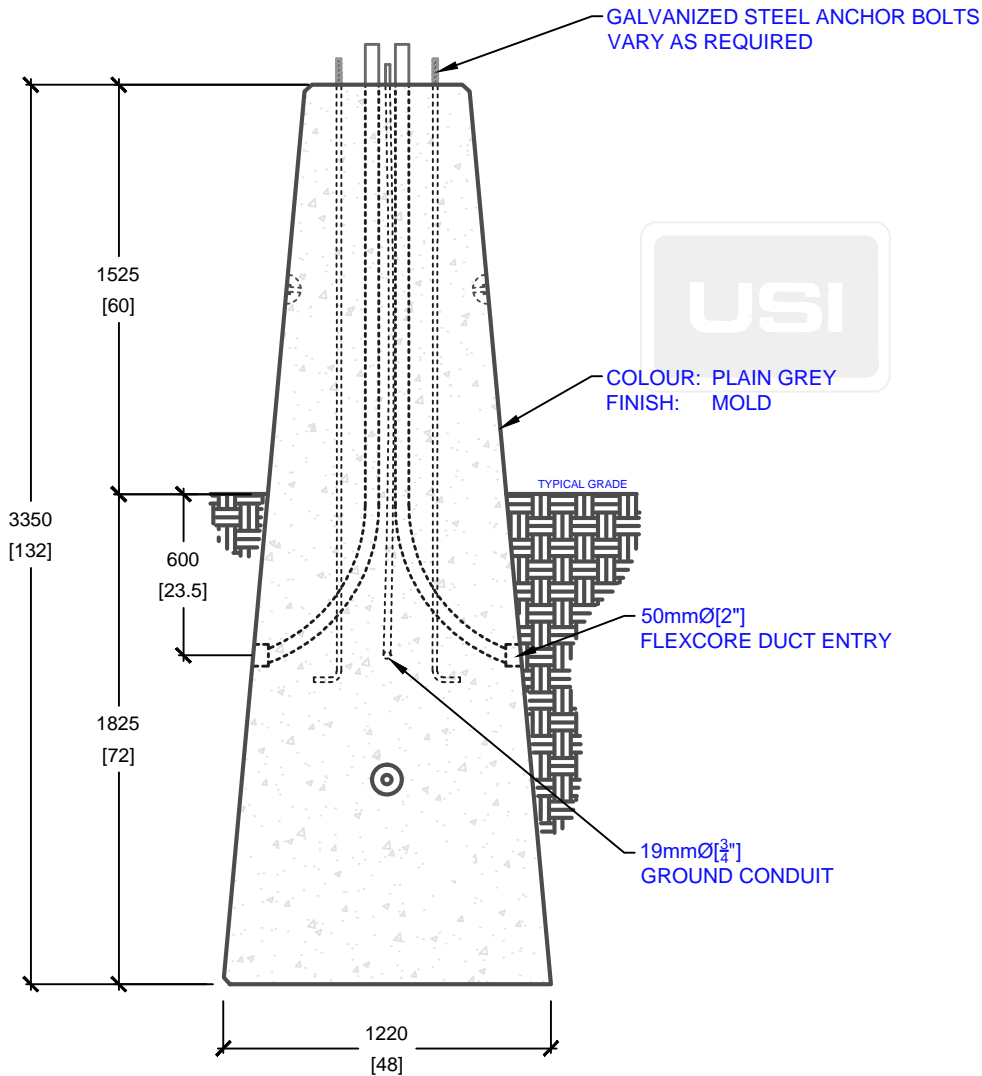

GALVANIZED STEEL ANCHOR BOLTS  
VARY AS REQUIRED

COLOUR: PLAIN GREY  
FINISH: MOLD

TYPICAL GRADE

50mmØ[2"]  
FLEXCORE DUCT ENTRY

19mmØ[¾"]  
GROUND CONDUIT

**SIDE VIEW**

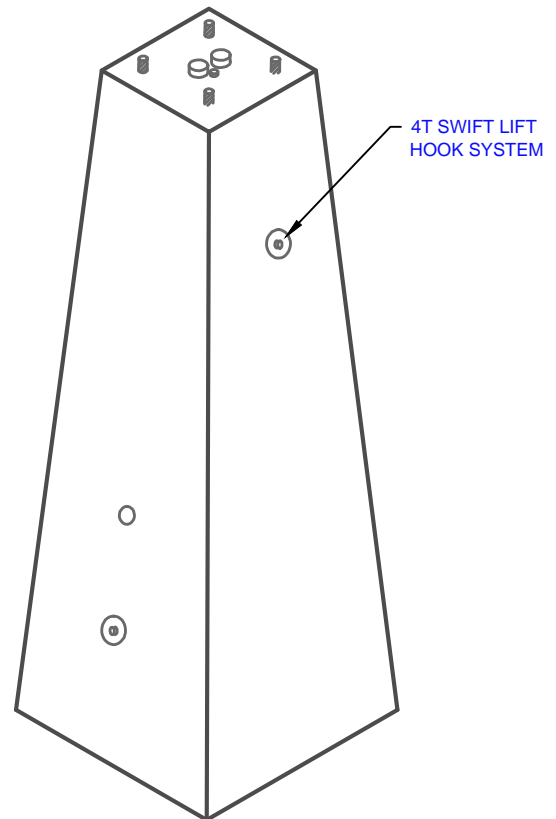

4T SWIFT LIFT  
HOOK SYSTEM

**ISOMETRIC VIEW**

mm  
[Inches]  
ALL DIMENSIONS DEFAULT TO MILLIMETRES



**UTILITY STRUCTURES INC.**

61 BONGARD AVE | OTTAWA, ON | K2E 6V2  
T: 613.225.6398 F: 613.225.1681 TF: 800.267.6466

[www.utilitystructures.com](http://www.utilitystructures.com)

**CONSTRUCTION DETAILS:**

- CAN ACCOMMODATE A 60' POLE ABOVE GRADE
- AVAILABLE IN VARIOUS COLOURS & FINISHES
- ADJUSTABLE BOLT CIRCLE DIAMETER
- BOLT CIRCLE DIAMETER: 200mm[8"] TO 510mm[20"]

- CSA 23.4-05
- 45 MPa (6525psi) AT 28 DAYS
- STRIPPING STRENGTH: MIN. 20 MPa(2900psi)
- 5-8% AIR ENTRAINED
- EXPOSURE CLASS: C-1
- REINFORCING: STEEL TO CSA CAN A23.1

**PRODUCT CODE:**

**E-52-132**

11' SQUARE PYRAMID POLE BASE

**INSIDE DIMENSIONS:**

**3.35m(H) X 1220mm x 1220mm**

**ESTIMATED TOTAL WEIGHT:**

**6,800 kg / 15,000 lbs**

**REVISION DATE:**

**MAY 17, 2017**

**REV. # 1**