

PRODUCT CODE	POLE HEIGHT (ft.)	BASE BURIAL DEPTH (ft.)	OVERALL LENGTH "X" (ft.)	WEIGHT (kg/lbs.)
E-50-20 (4)	10-15	4	4	1,070kg / 2,350lbs
E-50-20 (6.5)	16-30	6	6.5	1,750kg / 3,850lbs

* BASE BURIAL DEPTH SUBJECT TO SOIL CONDITIONS, REFER TO SOIL REPORT

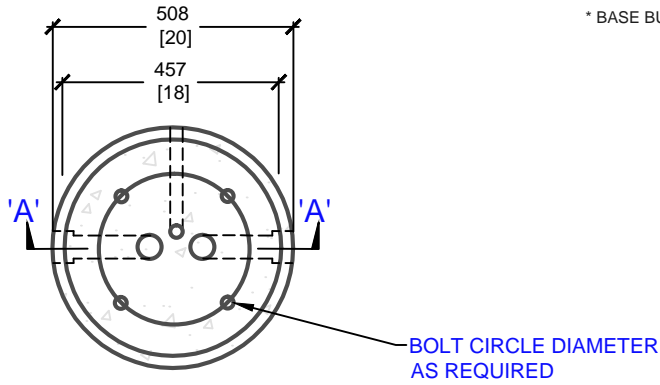

PLAN VIEW

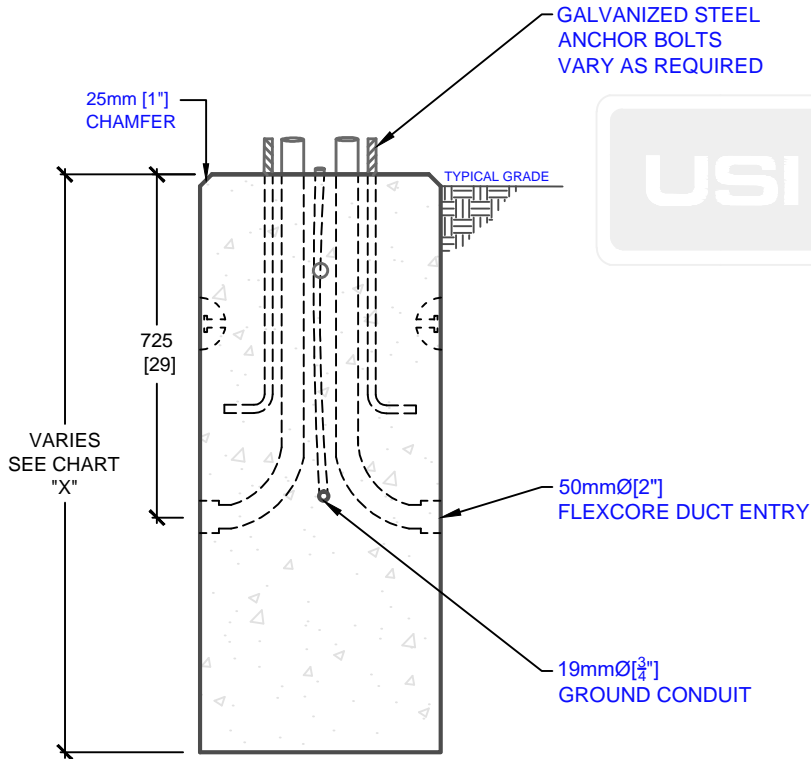

SIDE ELEVATION

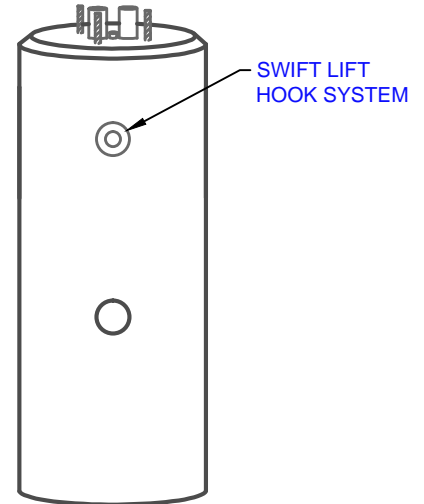

ISOMETRIC VIEW

mm
[Inches]
ALL DIMENSIONS DEFAULT TO MILLIMETRES



UTILITY STRUCTURES INC.

61 BONGARD AVE | OTTAWA, ON | K2E 6V2
T: 613.225.6398 F: 613.225.1681 TF: 800.267.6466

www.utilitystructures.com

CONSTRUCTION DETAILS:

- ACCOMMODATES VARIOUS POLE HEIGHTS
- ADJUSTABLE BOLT CIRCLE DIAMETER
- BOLT CIRCLE DIAMETER: 150mm[6"] TO 305mm[12"]

- CSA 23.4-05
- 35 MPa (5000psi) AT 28 DAYS
- STRIPPING STRENGTH: MIN. 20 MPa(2900psi)
- 5-8% AIR ENTRAINED
- EXPOSURE CLASS: C-1
- REINFORCING: STEEL TO CSA CAN A23.1

PRODUCT CODE:

E-50-20(H)
20" ROUND POLE BASE

DIMENSIONS:

VARIES(H) X 508mm dia.

TOTAL WEIGHT:

VARIES

REVISION DATE:

MAY 19, 2017

REV. # 1