

**CROSS SECTION 'A'**

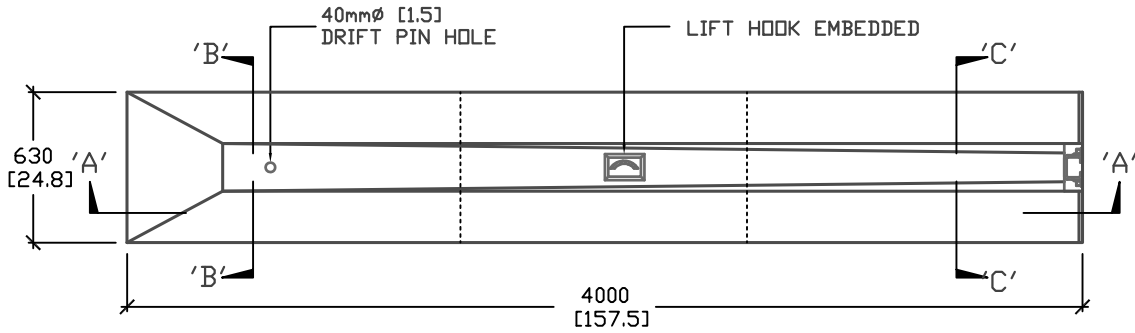

**PLAN VIEW**

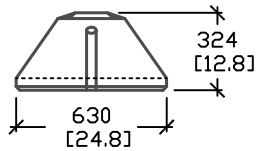

**CROSS SECTION 'B'**

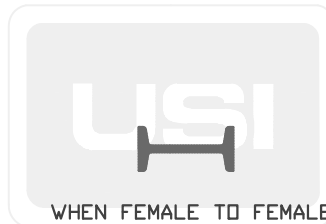

WHEN FEMALE TO FEMALE CONNECTION IS REQUIRED USE S100x14x800mm LONG STEEL I-BEAM



32mm $\phi$  x 1000mm DRIFT PIN

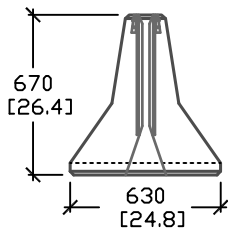

**CROSS SECTION 'C'**

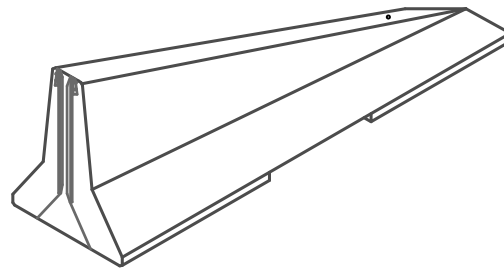

**ISOMETRIC VIEW**

ALL DIMENSIONS DEFAULT TO MILLIMETERS

mm [in.]



61 BONGARD AVE  
OTTAWA, ON,  
PH: 800.267.6466  
FAX: 613.225.1681

www.utilitystructures.com

**NOTES:**

AS PER O.P.S.D. 911.233  
USE WITH E46 TRANSITION

\*CSA 23.4-05  
35MPa (5000psi) AT 28 DAYS  
6-8% AIR ENTRAINED

REV.#	MM/DD/YYYY	PREP.
1	JULY/25/2008	LRW
2	MAR/01/2009	LRW

**E-47**

TAPER I-LOCK BARRIER

WEIGHT = 1678kg/3700lbs

**670mm(H) x 4000mm(L)**