

CROSS SECTION 'A'

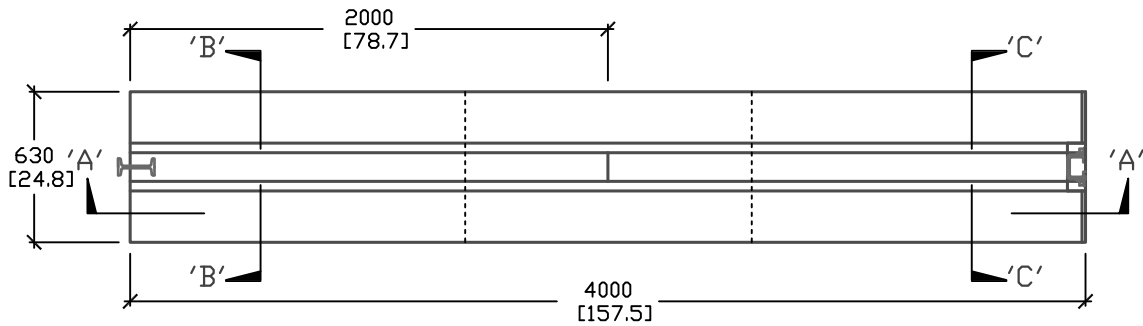

PLAN VIEW

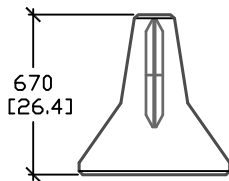

CROSS SECTION 'B'

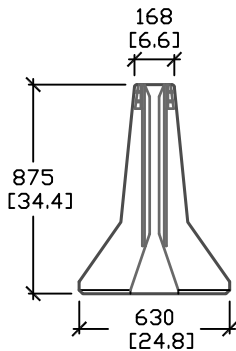

CROSS SECTION 'C'

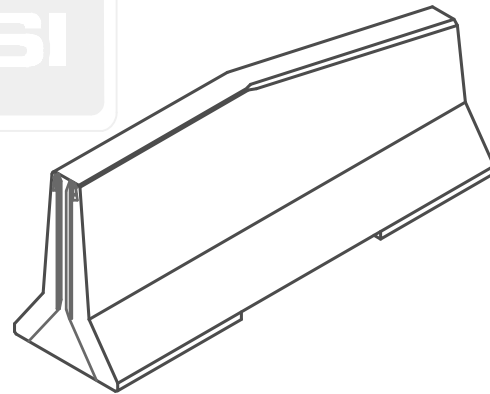

ISOMETRIC VIEW

ALL DIMENSIONS DEFAULT TO MILLIMETERS

mm
[in.]



61 BONGARD AVE
OTTAWA, ON,
PH: 800.267.6466
FAX: 613.225.1681

www.utilitystructures.com

NOTES:

AS PER O.P.S.D. 911.233
USE WITH E47 TAPER

*CSA 23.4-05
35MPa (5000psi) AT 28 DAYS
6-8% AIR ENTRAINED

REV.#	MM/DD/YYYY	PREP.
1	SEP/11/2008	LRW
2	MAR/01/2009	LRW

E-46

TRANSITION I-LOCK
BARRIER

WEIGHT = 2500kg/5000lbs

875mm(H) x 4000mm(L)