

**CROSS SECTION 'A'**

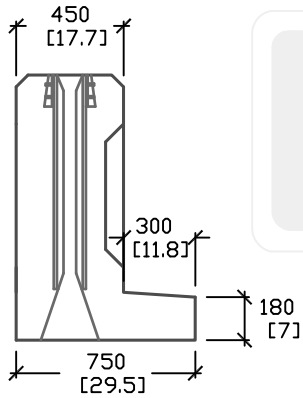

**CROSS SECTION 'B'**

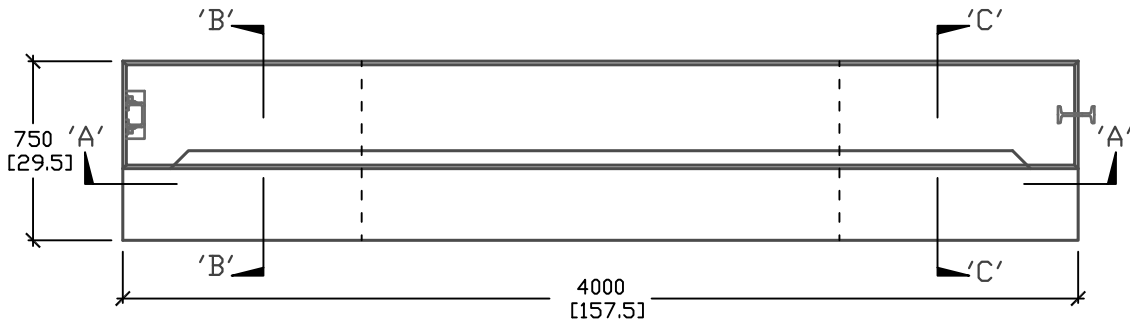
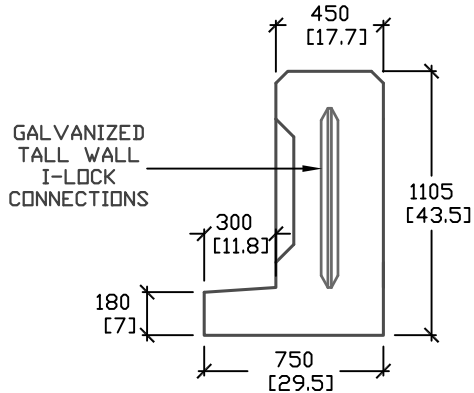

**CROSS SECTION 'C'**

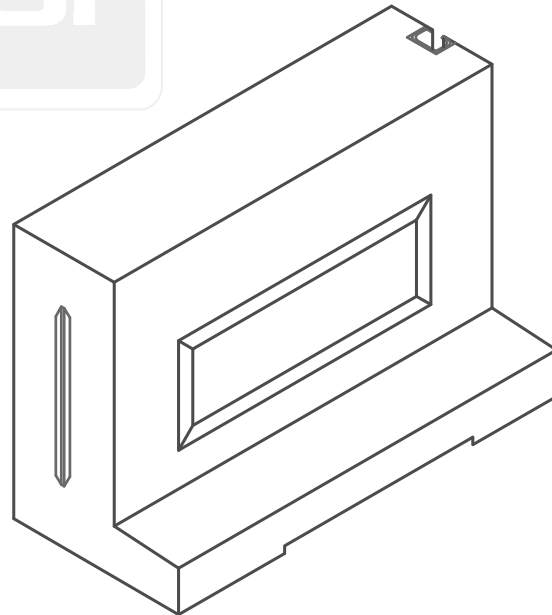

**ISOMETRIC VIEW**

ALL DIMENSIONS DEFAULT TO MILLIMETERS

mm  
[in.]



61 BONGARD AVE  
OTTAWA, ON,  
PH: 800.267.6466  
FAX: 613.225.1681

www.utilitystructures.com

**NOTES:**

AVAILABLE IN VARIOUS  
COLOURS AND FINISHES

\*CSA 23.4-05  
35MPa (5000psi) AT 28 DAYS  
6-8% AIR ENTRAINED

REV.#	MM/DD/YYYY	PREP.
1	AUG/06/2008	LRW
2	MAR/01/2009	LRW

**E-42F**

DECORATIVE SECURITY  
FLAT BARRIER

WEIGHT = 5180kg/11420lbs

**1.1m(H) x 4000mm(L)**