

CROSS SECTION 'A'

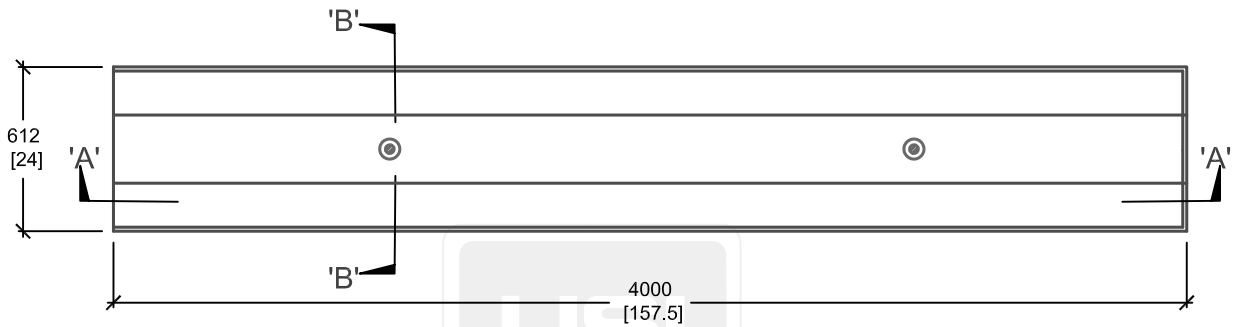

PLAN VIEW

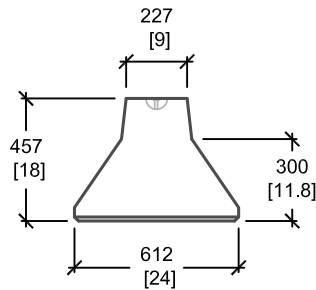

CROSS SECTION 'B'

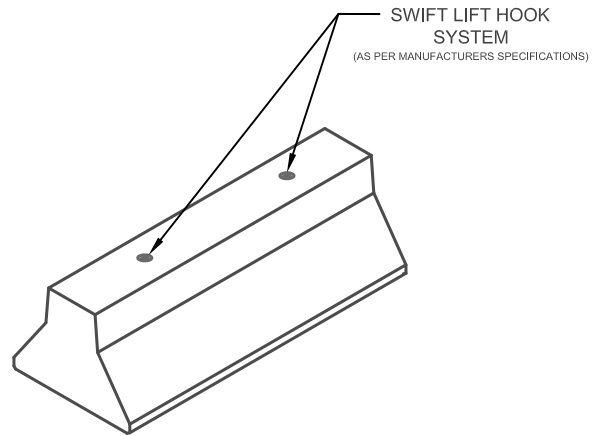

ISOMETRIC

mm
[Inches]
ALL DIMENSIONS DEFAULT TO MILLIMETRES



UTILITY STRUCTURES INC.

61 BONGARD AVE | OTTAWA, ON | K2E 6V2
T: 613.225.6398 F: 613.225.1681 TF: 800.267.6466

www.utilitystructures.com

CONSTRUCTION DETAILS:

- FLAT TOP BARRIER
- CUSTOM LENGTHS AVAILABLE
- USES:
- PARKING LOTS TO SUPPORT POLES & FENCES

- CSA 23.4-05
- 35 MPa (5000psi) AT 28 DAYS
- STRIPPING STRENGTH: MIN. 20 MPa(2900psi)
- 5-8% AIR ENTRAINED
- EXPOSURE CLASS: F-1
- REINFORCING: STEEL TO CSA CAN A23.1

PRODUCT CODE:

E-41LP

LOW PROFILE BARRIER

DIMENSIONS:

0.457m(H) x 4000mm

TOTAL WEIGHT:

1,678 kg / 3,700 lbs

REVISION DATE:

OCTOBER 15, 2015

REV. #3