

ELEVATION

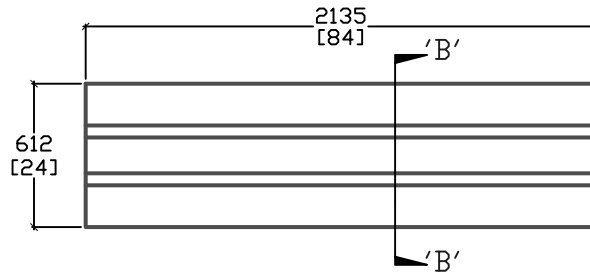

PLAN VIEW

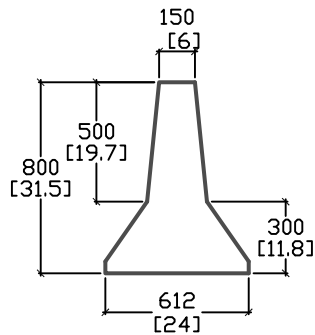

CROSS SECTION 'C'

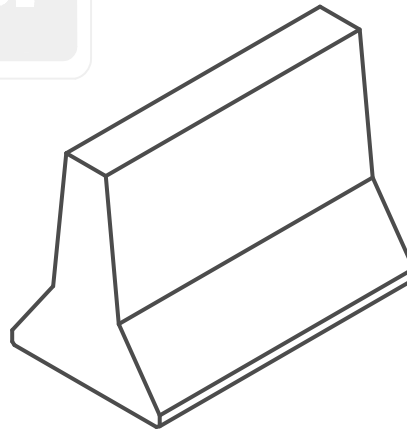

ISOMETRIC

ALL DIMENSIONS DEFAULT TO MILLIMETERS

mm
[in.]



61 BONGARD AVE
OTTAWA, ON,
PH: 800.267.6466
FAX: 613.225.1681

www.utilitystructures.com

NOTES:

AVAILABLE IN VARIOUS LENGTHS

*CSA 23.4-05
35MPa (5000psi) AT 28 DAYS
6-8% AIR ENTRAINED

REV.#	MM/DD/YYYY	PREP.
1	SEP/15/2008	LRW

E-41(7')

7' BARRIER

WEIGHT = 1211kg/2670lbs

800mm(H) x 2135mm(L)