

* AVAILABLE IN ANY LENGTH (MAXIMUM 4.0m) *

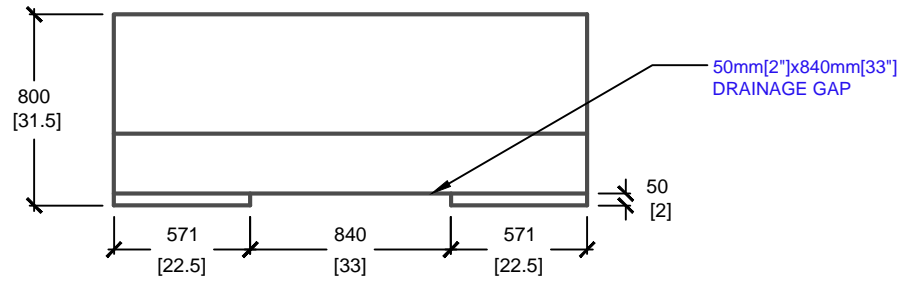

ELEVATION

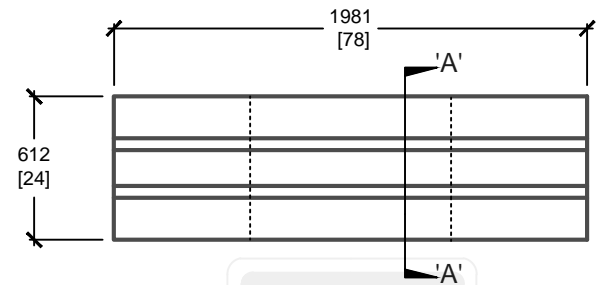

PLAN VIEW

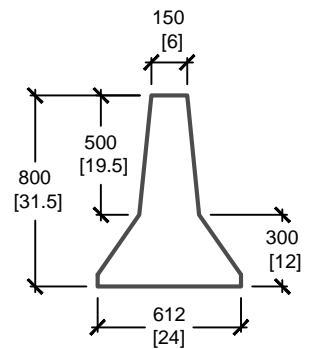

CROSS SECTION 'A'

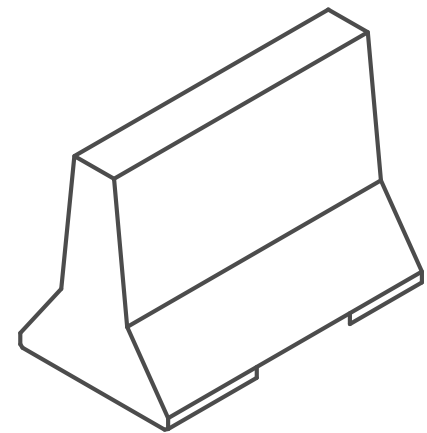

ISOMETRIC VIEW

mm [Inches]
ALL DIMENSIONS DEFAULT TO MILLIMETRES



UTILITY STRUCTURES INC.
61 BONGARD AVE | OTTAWA, ON | K2E 6V2
T: 613.225.6398 F: 613.225.1681 TF: 800.267.6466
www.utilitystructures.com

CONSTRUCTION DETAILS:

- AVAILABLE IN VARIOUS LENGTHS, COLOURS, AND FINISHES
- DRAINAGE GAP: 50mm[2"] x 840mm[33"]
- CSA 23.4-05
- 35 MPa (5000psi) AT 28 DAYS
- STRIPPING STRENGTH: MIN. 20 MPa(2900psi)
- 5-8% AIR ENTRAINED
- EXPOSURE CLASS: C-1
- REINFORCING: STEEL TO CSA CAN A23.1

PRODUCT CODE:	E-41(6.5')	
	6'6" SECURITY BARRIER	
DIMENSIONS:	800mm(H) x 2135mm(L)	
TOTAL WEIGHT:	1,125 kg / 2,475 lbs	
REVISION DATE:	JANUARY 4, 2018	REV. # 5