

PLAN VIEW

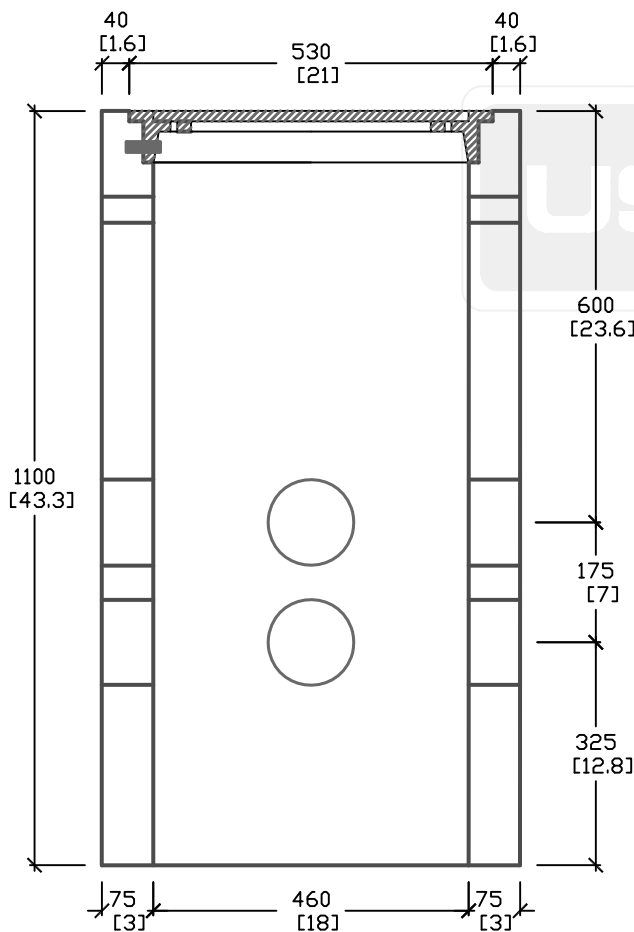

CROSS SECTION 'A'

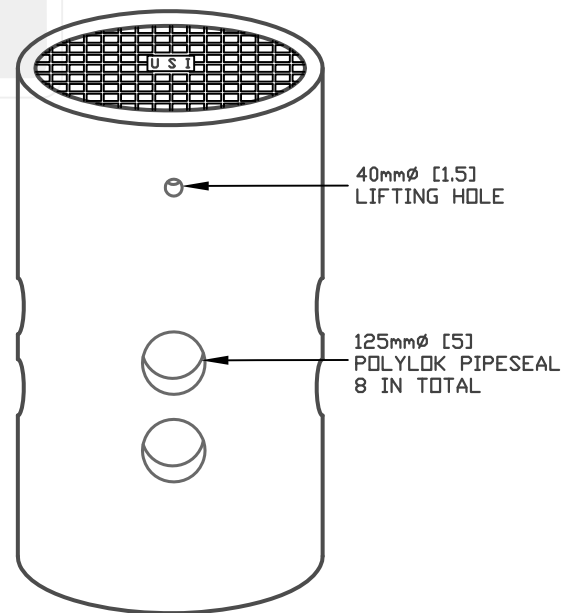

ISOMETRIC VIEW

ALL DIMENSIONS DEFAULT TO MILLIMETERS

mm
[in.]



61 BONGARD AVE
OTTAWA, ON,
PH: 800.267.6466
FAX: 613.225.1681

www.utilitystructures.com

NOTES:

FRAME AND COVER CAST IN
AS PER CITY OF TORONTO 802.005
AS PER CITY OF TORONTO 802.006

*CSA 23.4-05
35MPa (5000psi) AT 28 DAYS
6-8% AIR ENTRAINED

REV.#	MM/DD/YYYY	PREP.
1	AUG/01/2008	LRW
2	FEB/24/2009	LRW

E-32M

ELECTRICAL HANDHOLE

WEIGHT = 355kg/780lbs

1.1m(H) x 460mm dia.