

CROSS SECTION 'A'

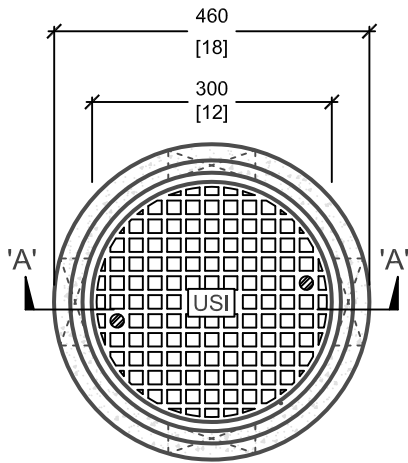

PLAN VIEW

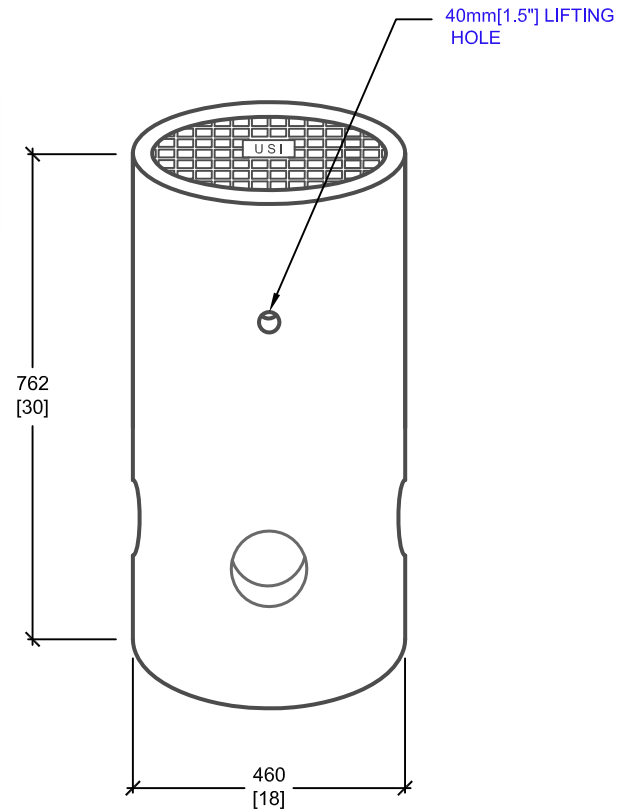

ISOMETRIC VIEW

mm
[Inches]
ALL DIMENSIONS DEFAULT TO MILLIMETRES



UTILITY STRUCTURES INC.

61 BONGARD AVE | OTTAWA, ON | K2E 6V2
T: 613.225.6398 F: 613.225.1681 TF: 800.267.6466

www.utilitystructures.com

CONSTRUCTION DETAILS:

- AS PER **OPSD 2112.01**
- **FRAME & COVER CAST IN TO CONCRETE**

- **CSA 23.4-05**
- 35 MPa (5000psi) AT 28 DAYS
- **STRIPPING STRENGTH: MIN. 20 MPa(2900psi)**
- 5-8% AIR ENTRAINED
- EXPOSURE CLASS: C-1
- **REINFORCING: STEEL TO CSA CAN A23.1**

PRODUCT CODE:

E-31

ELECTRICAL HANDHOLE

INSIDE DIMENSIONS:

0.76m(H) x 300mm DIA.

TOTAL WEIGHT:

220 kg / 480 lbs

REVISION DATE:

SEPTEMBER 11, 2017

REV. #4