

**CROSS SECTION 'A'**

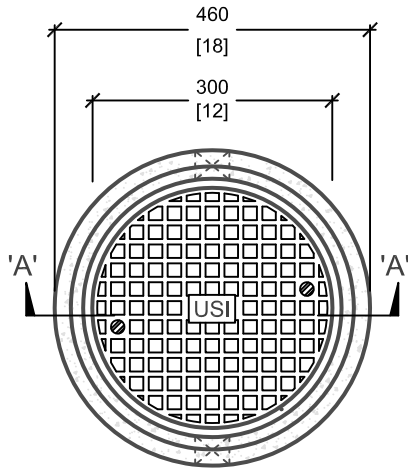

**PLAN VIEW**

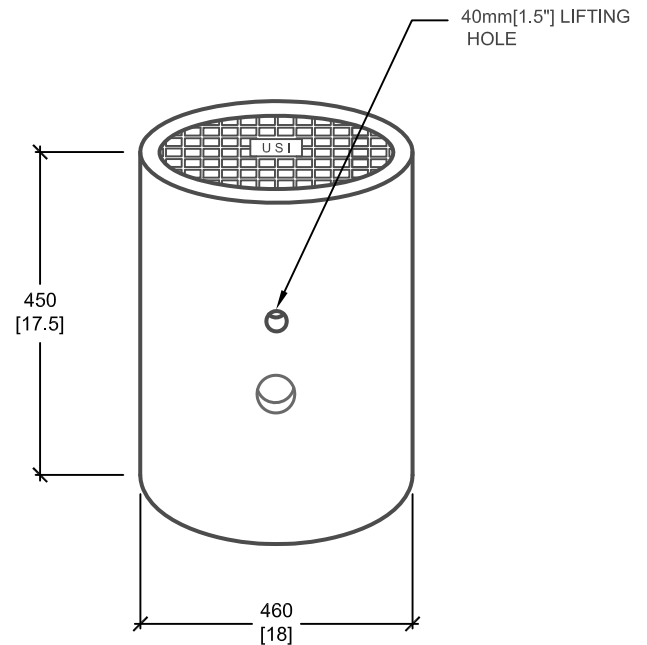

mm  
[Inches]  
ALL DIMENSIONS DEFAULT TO MILLIMETRES



**UTILITY STRUCTURES INC.**

61 BONGARD AVE | OTTAWA, ON | K2E 6V2  
T: 613.225.6398 F: 613.225.1681 TF: 800.267.6466

[www.utilitystructures.com](http://www.utilitystructures.com)

**CONSTRUCTION DETAILS:**

• **FRAME & COVER CAST IN TO CONCRETE**

- CSA 23.4-05
- 35 MPa (5000psi) AT 28 DAYS
- STRIPPING STRENGTH: MIN. 20 MPa(2900psi)
- 5-8% AIR ENTRAINED
- EXPOSURE CLASS: F-1
- REINFORCING: STEEL TO CSA CAN A23.1

**PRODUCT CODE:**

**E-30**

ELECTRICAL HANDHOLE

**INSIDE DIMENSIONS:**

**0.45m(H) x 300mm DIA.**

**TOTAL WEIGHT:**

**150 kg / 330 lbs**

**REVISION DATE:**

**OCTOBER 9, 2015**

REV. #1