

PLAN VIEW

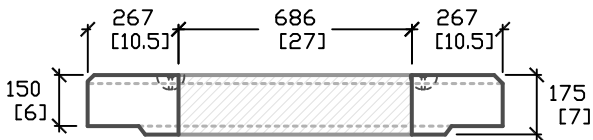

SWIFT LIFT HOOK SYSTEM

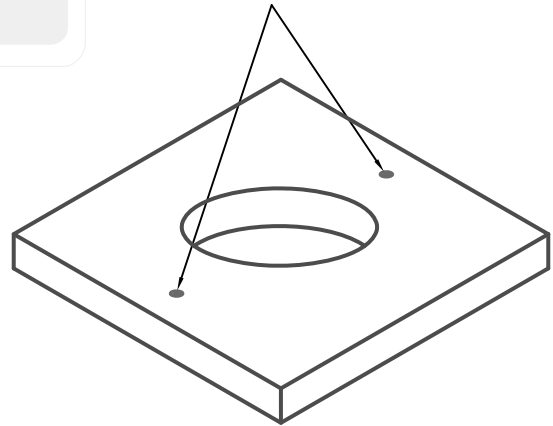

CROSS SECTION 'A'

ISOMETRIC VIEW

ALL DIMENSIONS DEFAULT TO MILLIMETERS

mm
[in.]



61 BONGARD AVE
OTTAWA, ON,
PH: 800.267.6466
FAX: 613.225.1681

DESIGNED FOR CL-625-ONT TRUCK
LIVE LOADING AS PER CSA S6-06

USE WITH BASE E1B
CAN ALSO USE THE E1 BASE

*CSA 23.4-05
35MPa (5000psi) AT 28 DAYS
6-8% AIR ENTRAINED

E-3

ELECTRICAL
MANHOLE PAD

WEIGHT = 420kg/900lbs

www.utilitystructures.com

REV.#	MM/DD/YYYY	PREP.
2	FEB/26/2009	LRW
3	NOV/06/2013	EG

1220mm x 1220mm [O.D.]