

CROSS SECTION 'A'

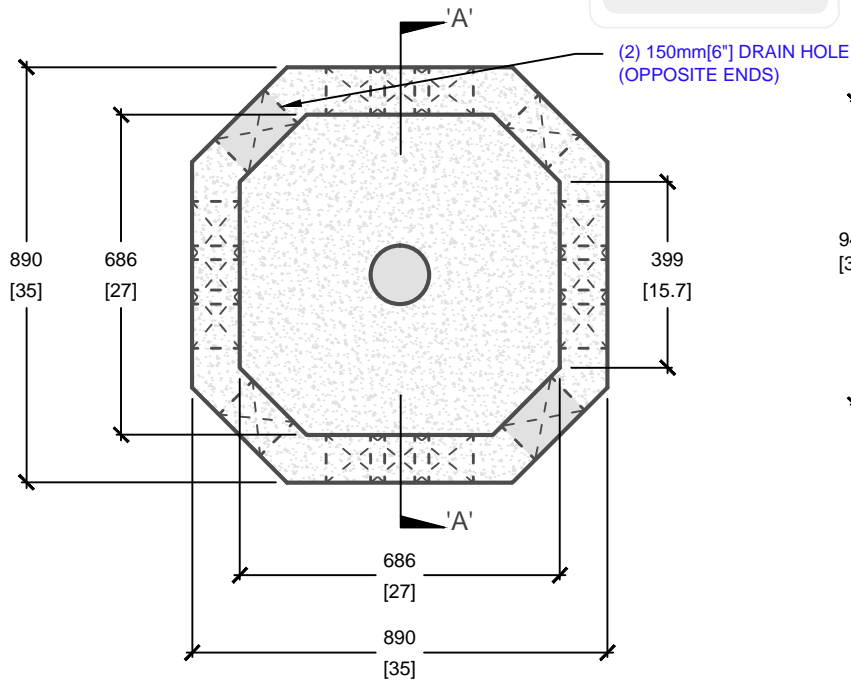

PLAN VIEW

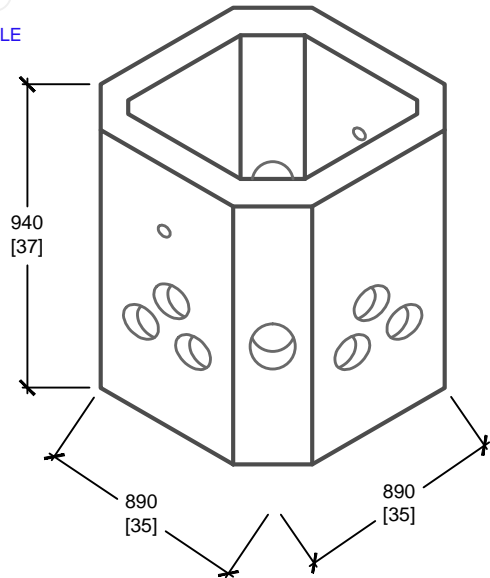

ISOMETRIC VIEW

mm
[Inches]
ALL DIMENSIONS DEFAULT TO MILLIMETRES



UTILITY STRUCTURES INC.

61 BONGARD AVE | OTTAWA, ON | K2E 6V2
T: 613.225.6398 F: 613.225.1681 TF: 800.267.6466

www.utilitystructures.com

CONSTRUCTION DETAILS:

• AS PER CITY OF OTTAWA LID004D & T4

- CSA 23.4-05
- 35 MPa (5000psi) AT 28 DAYS
- STRIPPING STRENGTH: MIN. 20 MPa(2900psi)
- 5-8% AIR ENTRAINED
- EXPOSURE CLASS: C-1
- REINFORCING: STEEL TO CSA CAN A23.1

PRODUCT CODE:

E-28

ELECTRICAL TRAFFIC OCTAGONAL HANDHOLE

INSIDE DIMENSIONS:

0.94m(H) x 690mm x 690mm

TOTAL WEIGHT:

650 kg / 1,430 lbs

REVISION DATE:

SEPTEMBER 08, 2017

REV. #6