

PLAN VIEW

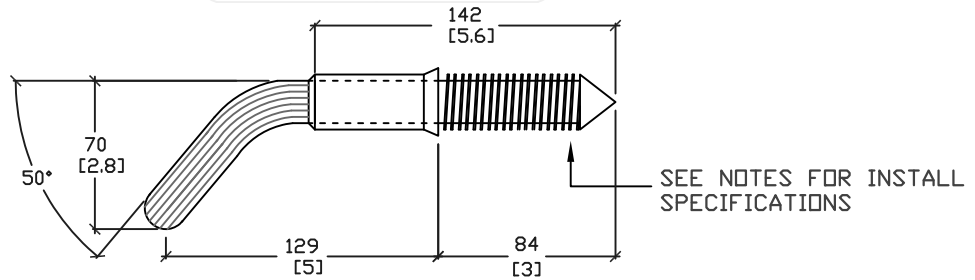

FRONT VIEW



END VIEW

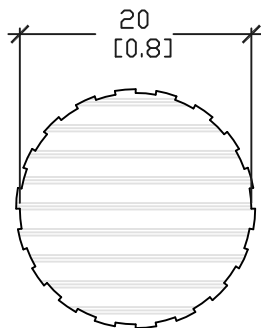

CROSS SECTION 'A'

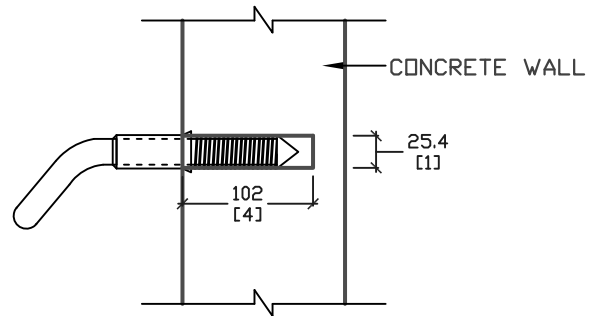

UNIT INSTALLED

ALL DIMENSIONS DEFAULT TO MILLIMETERS

mm [in.]



61 BONGARD AVE  
OTTAWA, ON,  
PH: 800.267.6466  
FAX: 613.225.1681

www.utilitystructures.com

NOTES:

DRILL 24.5mmØ [1"Ø] HOLE  
101.6MM [4"] DEEP  
AS PER D.P.S.D. #405.02  
SOLID ALUMINUM

REV.#	MM/DD/YYYY	PREP.
1	SEP/16/2008	LRW

# 16" ALUMINUM STEP

WEIGHT = N/A

**406mm WIDE**